

SNACKSHOP 6000

SNACKSHOP 6000 XL

SNACKSHOP 6000

SNACKSHOP 6000 XL

instruction manual for

SNACKSHOP 6000

SNACKSHOP 6000 XL



Automatic Products
international, ltd.

75 WEST PLATO BOULEVARD • ST. PAUL, MINNESOTA 55107-2095

WARRANTY

The Automatic Products Company warrants this vendor, manufactured by it, to be free from defects in material or workmanship under normal use. Our obligation under this warranty is to the original purchaser only and is limited to making good at our factory any part or parts thereof which shall, within two (2) years after delivery of such product to the original purchaser, be returned to us or to our authorized dealer or distributor from whom purchased with all transportation charges prepaid to our factory, and which our examination shall disclose to our satisfaction to have been defective.

This warranty does not extend: 1: To any of our products which have been subjected to misuse, neglect, accident, incorrect wiring, improper installation, or to use in violation of instructions furnished by us; 2: To units which have been repaired or altered outside of our factory; 3: To cases where the serial number of the product has been removed, defaced or changed; 4: To electrical components, lamps, tubes or circuit breakers; 5: To accessories not of our own manufacture used with our products. Any part manufactured by Automatic Products Company, found by us to be defective within the warranty period will be exchanged by Automatic Products Company or their

authorized dealer or distributor without charge to the owner.

This warranty applies only to our products which are used within the United States of America, and is in lieu of all warranties expressed or implied, including, but not limited to implied warranties of merchantability or fitness for a particular purpose, and no representative or person is authorized to assume for us any other liability in connection with the sale of our products.

The Automatic Products Company reserves the right to make any changes or improvements in its products without notice and without obligation, and without being required to make corresponding changes or improvements in products theretofore manufactured or sold.

AUTOMATIC PRODUCTS COMPANY
75 West Plato Boulevard
St. Paul, Minnesota 55107

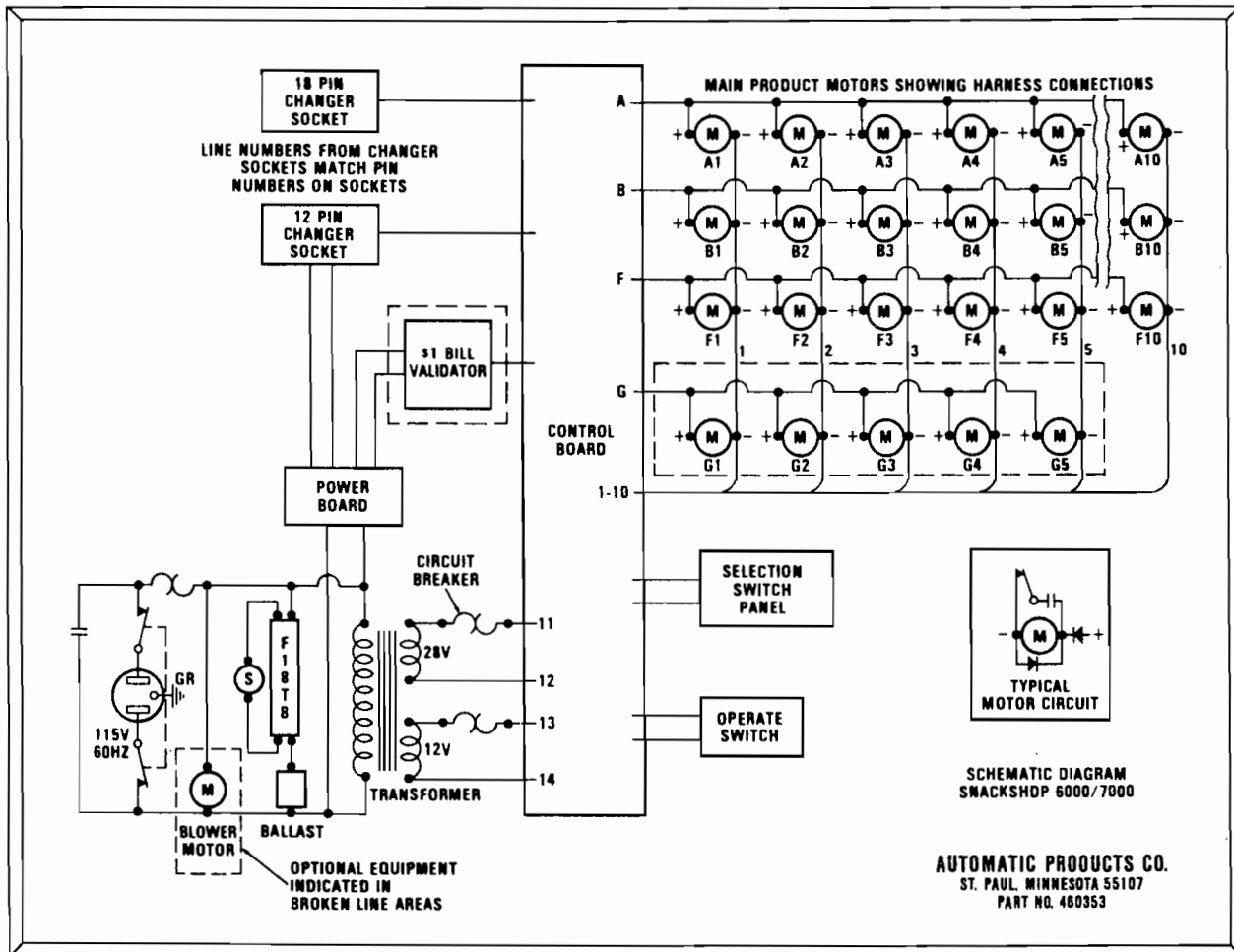

Snackshop 6000 and 6000XL have been designed from superior engineering and with quality throughout. They have been built of rugged construction for many years of reliable trouble-free operation. Note: (For indoor use only)

To achieve the most economical trouble-free operation from your Snackshop 6000 and 6000XL, it is recommended that this service manual be thoroughly read and instructions followed pertaining to all loading and servicing, etc. of the vendor.

6000 capacities

Unless otherwise specified machine will be shipped with spiral assortment shown below.
 Figures in circles represent capacities in each spiral.

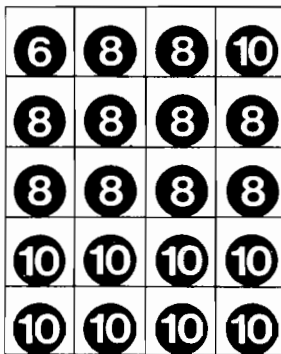

MODEL 6520
 Capacity as shown: 176 units.

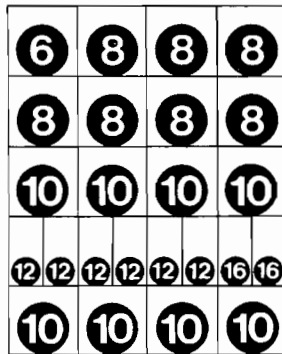

MODEL 6524
 Capacity as shown: 246 units.

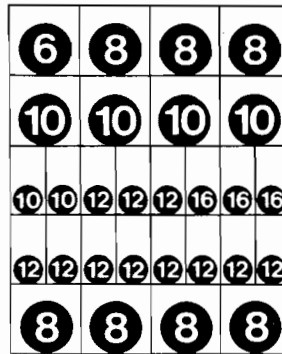

MODEL 6528
 Capacity as shown: 302 units.

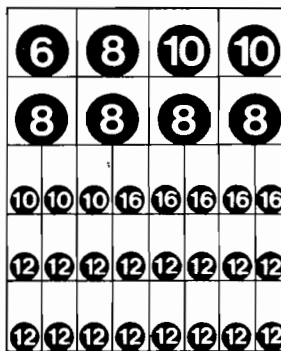

MODEL 6532
 Capacity as shown: 368 units.

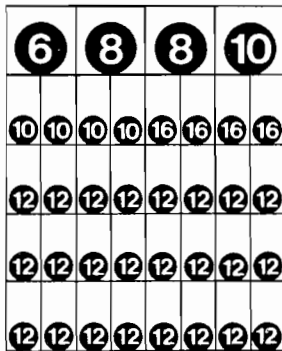

MODEL 6536
 Capacity as shown: 424 units.

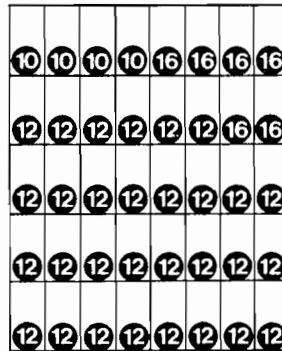

MODEL 6540
 Capacity as shown: 496 units.

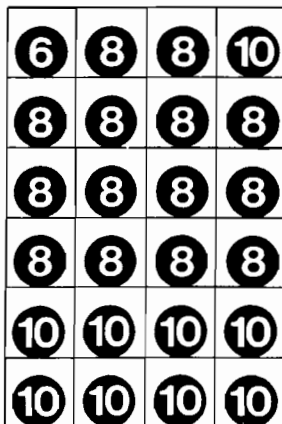

MODEL 6624
 Capacity as shown: 208 units.

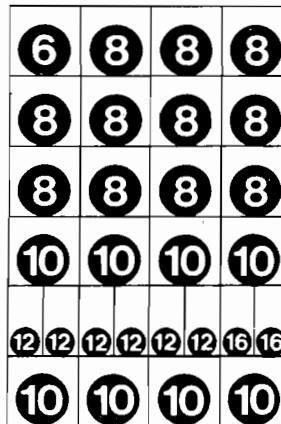

MODEL 6628
 Capacity as shown: 278 units.

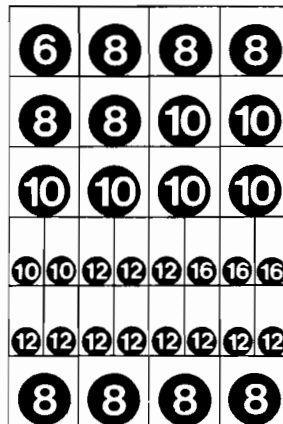

MODEL 6632
 Capacity as shown: 338 units.

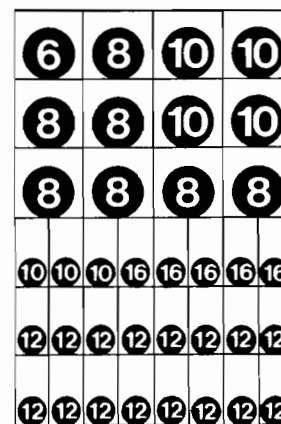

MODEL 6636
 Capacity as shown: 404 units.

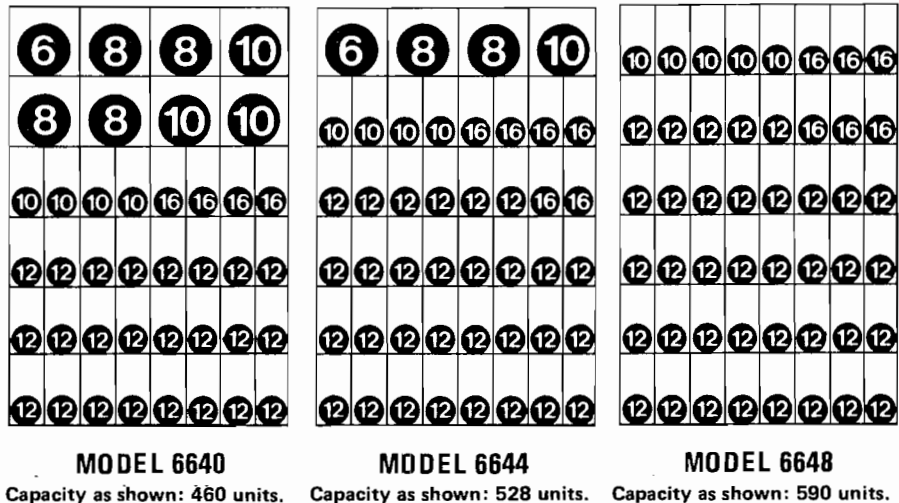

PRODUCT SIZE CAPABILITY

Shelves	Height	Width of Snack Shelves Only	Width of Candy Shelves Only	Depth of Snack Spirals only Choice:	Depth of Candy Spirals only Choice
Top	7-3/4	2-1/2" to 5-1/4"	1" to 2-1/4"		
Second	7-1/4	2-1/2" to 5-1/4"	1" to 2-1/4"	6 - Item Spiral 2-1/16"	10 - Item Spiral 1-5/16"
Third	6-3/8	2-1/2" to 5-1/4"	1" to 2-1/4"	8 - Item Spiral 1-11/16"	12 - Item Spiral 1-1/16"
Fourth	7-1/8	2-1/2" to 5-1/4"	1" to 2-1/4"	10 - Item Spiral 1-5/16"	16 - Item Spiral 3/4"
Fifth	6-1/2"	2-1/2" to 5-1/4"	1" to 2-1/4"		20 - Item Spiral 1/2"
Sixth	5-7/8"	2-1/2" to 5-1/4"	1" to 2-1/4"		

Eight selection shelves for candy and other narrow items fit on all six positions.

Spiral of one item capacity can be freely interchanged with any other of the same diameter.

Boxed items may need slightly larger clearances to vend properly.

Movable spacers available to adjust widths to ranges shown in each selection.

Gum and Mint Capacity: It is difficult to determine the true capacity due to variations of product size. The average capacity for the Gum and Mint stack is 90 items.

Should you have questions pertaining to this manual or the vendor please contact your local Automatic Products Company distributor or write directly to:

Service Manager
Automatic Products Company
75 West Plate Boulevard
St. Paul, Minnesota 55107

SPECIFICATIONS – 6000

HEIGHT – 72"

WIDTH – 33"

DEPTH – 27-5/8"

FLOOR SPACE REQUIRED – 6.4 SQ. FT.

SHIPPING CONTAINER SIZE – 45.5 CU. FT.

POWER REQUIREMENTS – 115 V., 60 HZ.

STANDBY AMPERES – .7 OPERATING AMPERES – 3

6000XL capacities

Unless otherwise specified machine will be shipped with spiral assortment shown below. Figures in circles represent capacities in each spiral.

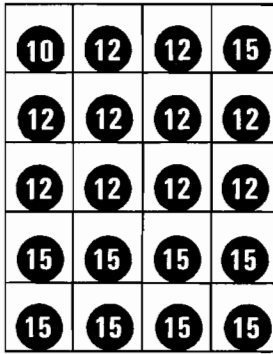

MODEL 6520 XL
Capacity as shown: 265 units.

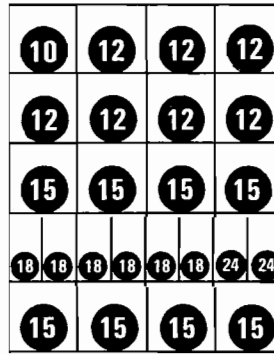

MODEL 6524 XL
Capacity as shown: 370 units.

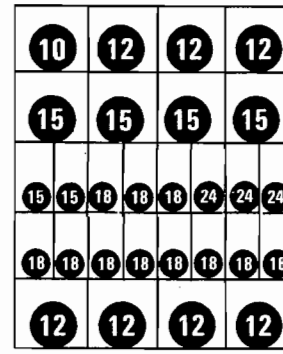

MODEL 6528 XL
Capacity as shown: 442 units.

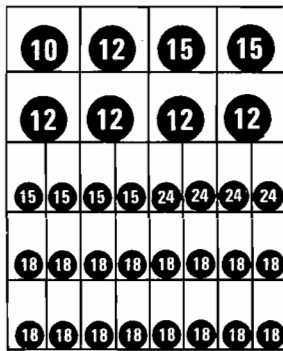

MODEL 6532 XL
Capacity as shown: 544 units.

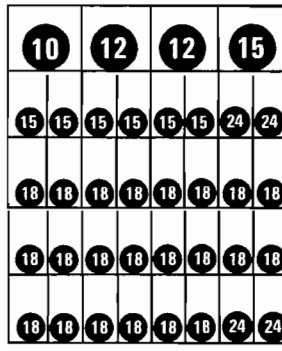

MODEL 6536 XL
Capacity as shown: 631 units.

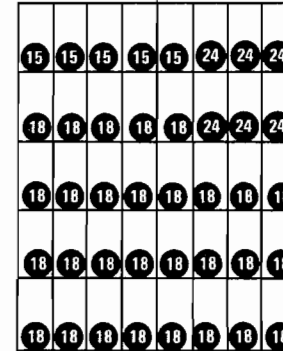

MODEL 6540 XL
Capacity as shown: 741 units.

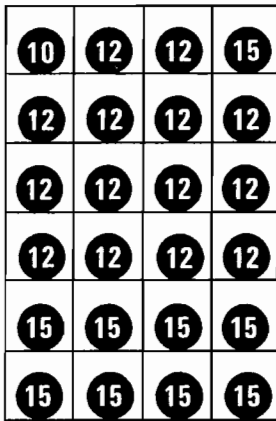

MODEL 6624 XL
Capacity as shown: 313 units.

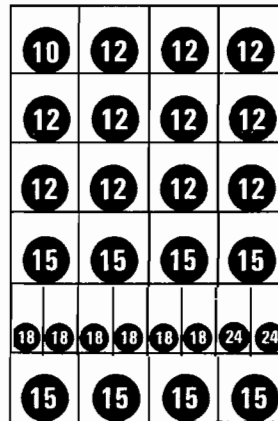

MODEL 6628 XL
Capacity as shown: 418 units.

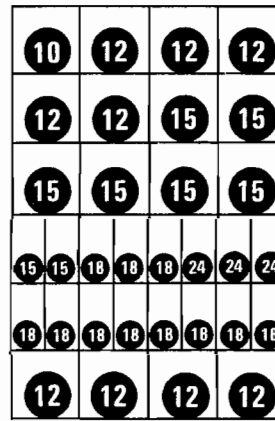

MODEL 6632 XL
Capacity as shown: 508 units.

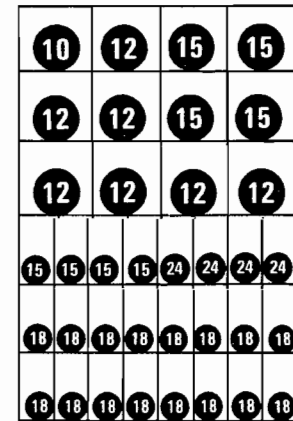

MODEL 6636 XL
Capacity as shown: 598 units.

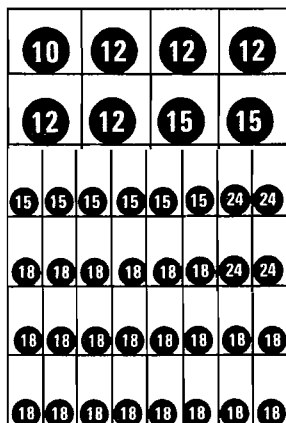

MODEL 6640 XL

Capacity as shown: 682 units.

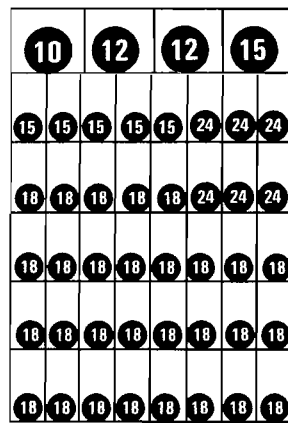

MODEL 6644 XL

Capacity as shown: 790 units.

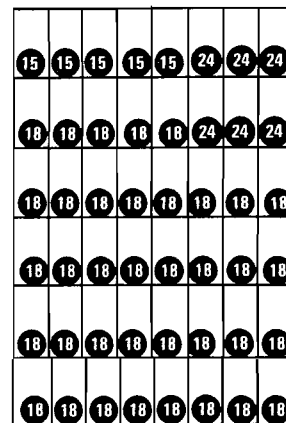

MODEL 6648 XL

Capacity as shown: 885 units.

PRODUCT SIZE CAPABILITY

Shelves	Height	Width of Snack Shelves Only	Width of Candy Shelves Only	Depth of Snack Spirals only Choice:	Depth of Candy Spirals only Choice
Top	7-3/4	2-1/2" to 5-1/4"	1" to 2-1/4"		12 - Item Spiral 1-7/8"
Second	7-1/4	2-1/2" to 5-1/4"	1" to 2-1/4"	7 - Item Spiral 2-1/2"	15 - Item Spiral 1-5/16"
Third	6-3/8	2-1/2" to 5-1/4"	1" to 2-1/4"	10 - Item Spiral 2-1/16"	18 - Item Spiral 1-1/16"
Fourth	7-1/8	2-1/2" to 5-1/4"	1" to 2-1/4"	12 - Item Spiral 1-11/16"	24 - Item Spiral 3/4"
Fifth	6-1/2	2-1/2" to 5-1/4"	1" to 2-1/4"	15 - Item Spiral 1-5/16"	30 - Item Spiral 1/2..
Sixth	5-7/8"	2-1/2" to 5-1/4"	1" to 2-1/4"		

Eight selection shelves for candy and other narrow items fit on all six positions.

Spiral of one item capacity can be freely interchanged with any other of the same diameter.

Boxed items may need slightly larger clearances to vend properly.

Movable spacers available to adjust widths to ranges shown in each selection.

Gum and Mint Capacity: It is difficult to determine the true capacity due to variations of product size. The average capacity for the Gum and Mint shelf is 135 items.

SPECIFICATIONS – 6000XL

HEIGHT – 72"

WIDTH – 33"

DEPTH – 35"

FLOOR SPACE REQUIRED – 8.1 SQ. FT.

SHIPPING CONTAINER SIZE – 58.1 CU. FT.

POWER REQUIREMENTS – 115V., 60 HZ.

STANDBY AMPERES – .7 OPERATING AMPERES – 3

unpacking

The Snackshop 6000 and 6000XL are assembled and packed so that a minimum amount of time is necessary for preparation to install it on location. The following steps are recommended to insure correct unpacking.

1. **Shipping Damage:** Thoroughly inspect the exterior of the carton for damage which may have occurred during shipment. Report any damage to delivering carrier and follow their instructions.
2. Remove staples from lower edge and those at top of carton, and slit carton vertically at the taped corner. Open and remove carton. Remove the remainder of the packing material. On machines shipped with lock in place, the keys are stapled to the carton base.
3. **Remove Vendor With A Fork Lift Truck:** Remove the carton from the vendor. From the front of the vendor tip the vendor backward and run forks under the cabinet.

4. **Removing Vendor Without A Fork Lift Truck:** Remove the carton from the vendor. Break off the thin piece of board behind the rear legs. From the front of the machine tip the vendor back enough to clear the lower legs from the holes in the front board. Push the machine back off the base. Remove the pallet.

NOTE: Because the weight concentration is toward the back of the cabinet, trucking and lifting should be done from the back. CAUTION should be taken when trucking from side.

5. On machines with lock in place, unlock, and turn handle to open door. When no lock is furnished, remove tape and turn handle. Swing door to its full open position.
6. Remove all packing tape and paper from various areas of machine and the shipping strap.
7. **Warranty:** The warranty card is attached to the cover of this manual. It must be filled out in full and mailed at once to insure coverage.

installation

1. **LEVELING THE MACHINE** on location is important for the proper function of the machine. The four leveling screws in the legs are the means of leveling the machine. After positioning the machine, level machine in front to rear and right to left directions. After leveling, turn front right (lock side) leveling screw in about one-half turn to drop this corner slightly to make the door easier to close and lock.
2. **THE MAIN POWER CORD** is shipped fully inside the machine. Extend it through the hole located in the base on the left (hinge side) of the machine behind the transformer. Install the plate with key hole slots over the two screws in the base by the cord hole and drive screws tight to hold cord in place. Plug the 3 pin grounded plug into a properly grounded 115V 60 HZ outlet only.

In order to comply with electrical safety regulations and Underwriters Laboratories requirements, all electrical equipment must be properly polarized and grounded. The Snackshop 6000 and 6000XL are wired so that they are properly polarized in accordance with the electrical code. If the wall outlet is wired and grounded properly, then the vendor will connect properly.

Shown in View A & B are two properly grounded and polarized wall outlets. One is a three wire grounding type wall outlet (see View A) and one is a two wire wall outlet (see View B) with an adapter in place. To make a polarity check use a 115 volt neon test lamp as shown or a volt ohm meter. The hot side of the circuit should always be counterclockwise from the ground terminal (which should be at the bottom).

Should the polarity at the wall outlet show any way other than that shown below, the outlet should be rewired.

3. **LOADING SNACK SHELVES:** Open door to full open position, push down on white plastic lock lever (Figure 1) on right side panel by shelf to unlock shelf, holding lever down. Grasp the shelf, under both front corners (see Fig-

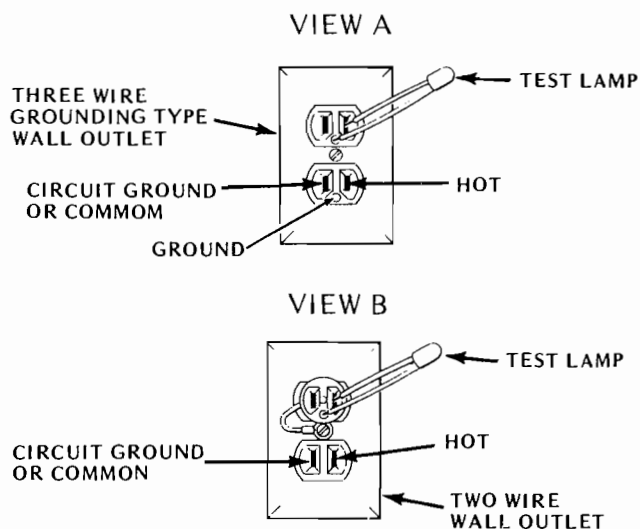

ure 1), lift front shelf slightly and pull forward until shelf reaches its stop. The shelves tilt down (do not drop) to make loading easier. **Only one product shelf should be in the loading position at a time.** When returning a shelf, be sure the shelf is in its full home or vend position. Begin loading with the top shelf. Move it to the loading position. The height spacing for items is greatest in this shelf and the tallest bagged items should be placed there. Soft items, such as pastry, pies, etc., should be placed in the lowest snack shelf, making the drop distance as short as possible.

IMPORTANT: Product must not be forced into the spiral spaces but should fit freely. If the product is too tight, use a larger pitch spiral. The bottom of the product should be placed on top of the spiral wire that rests on the shelf surface (see Figure 2). The width of the product must be greater than the diameter of the snack spiral. If it is smaller, the product may fall through when it is in the front, ready to vend position.

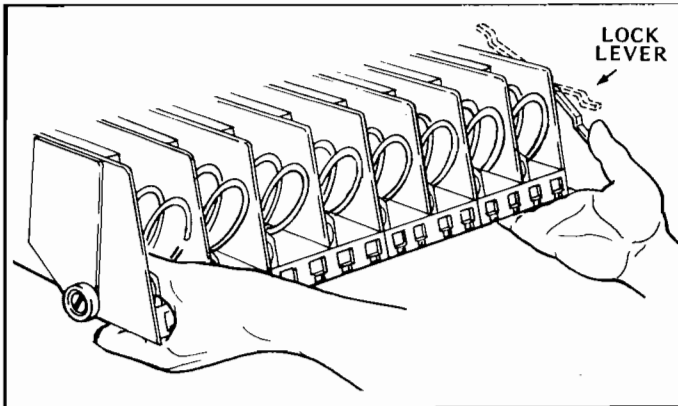

Figure 1. MOVING SHELF TO LOADING POSITION.

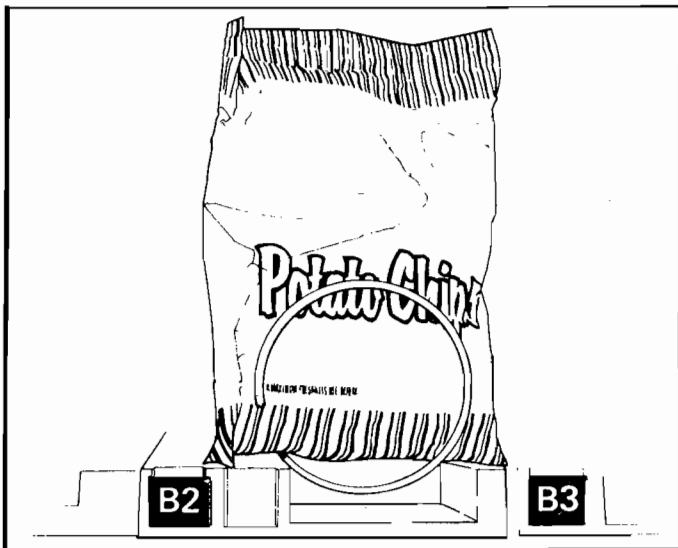

Figure 2. PLACEMENT OF PRODUCT ON MAIN PRODUCT SNACK SHELVES AND FRONT END POSITION OF SPIRAL.

4. REMOVAL OF SPIRAL: Grasp the front of the spiral and turn it clockwise. Lift the spiral up and off of the spiral lock. When replacing a spiral attach it around the tab on the spiral lock and turn the spiral counterclockwise to lock it in place. Be sure the front end of the spiral is positioned properly (with the front end of the spiral pointing downward on the left side) (see Figure 3). The spiral lock is attached between the spiral retainer tabs. Give a light forward pull on front of the spiral to check if it is locked in place.

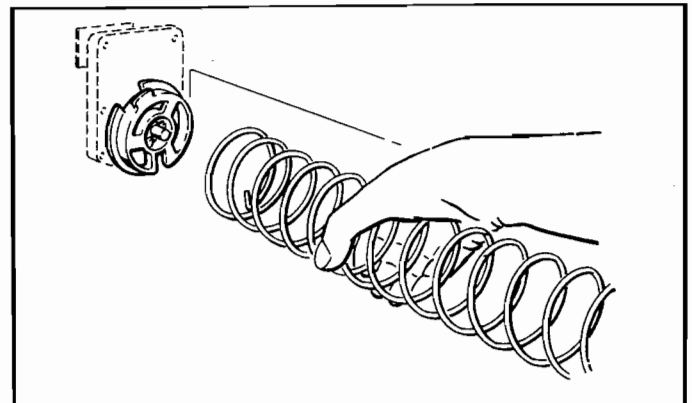

Figure 3. REMOVING AND INSTALLING SPIRAL.

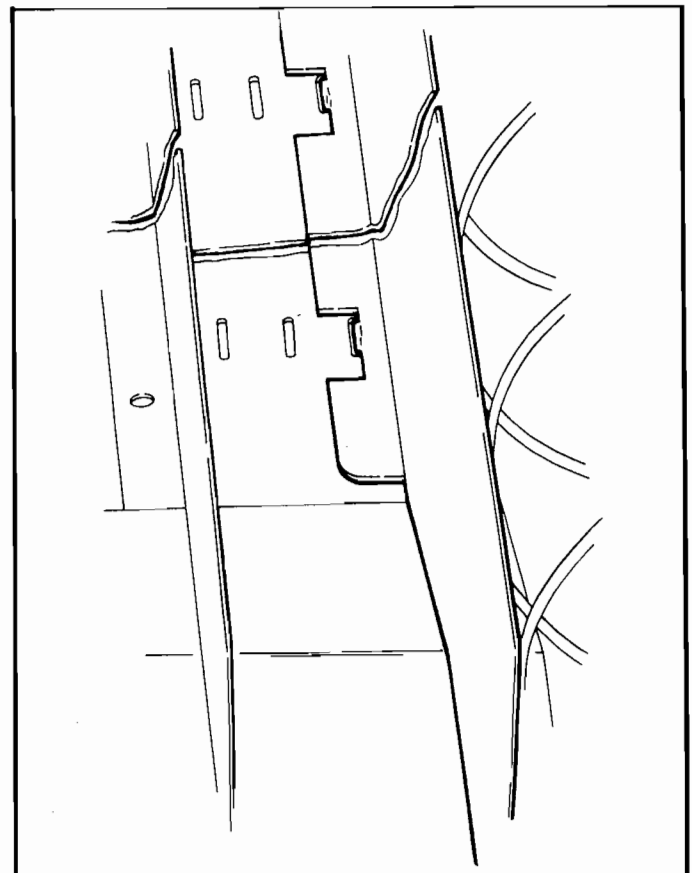

Figure 4. ALIGNMENT OF MOVEABLE PRODUCT SPACERS.

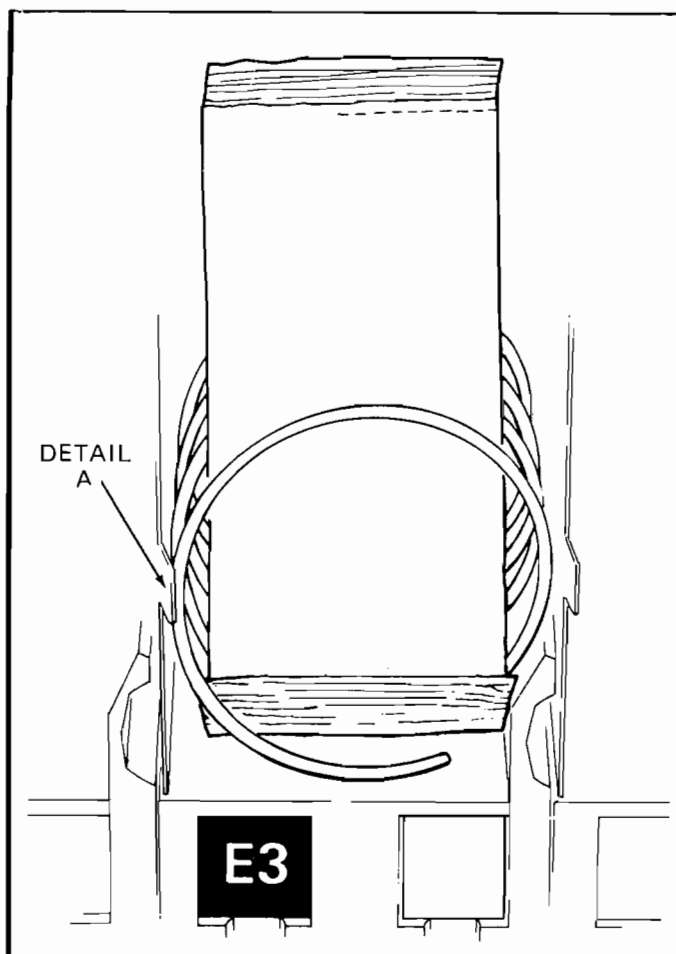

Figure 5. PLACEMENT OF PRODUCT ON MAIN PRODUCT CANDY SHELVES AND FRONT END POSITION OF SPIRAL.

5. **PRODUCT SPACERS—4 SELECTION SHELF:** A product spacer is used to reduce the width of the product area and should be used on any 4-selection snack shelf where the product width is 4½" or less. Spacers should fit within 1/8" of the product but should not fit tight against the product. There are three positions in each snack space where these spacers can be placed. To install the spacer, align the lock ears (on the lower edge of the spacer) with one of the three sets of slots (one front and one rear). (See Figure 4). Push the spacer to the rear to allow the ears to enter the slots, then allow the spacer to move forward. Be sure the ears are in the same set of slots, front and rear. (See Figure 4). Continue loading all spirals adjust with spacers where needed in the top shelf. Return the top shelf to the vend position and following this procedure load the remainder of the large spiral shelves. The shelf divider separating the right (lock side) column from the next column is movable to allow vending of products wider than 5½" in the second column. If this is used the right column must be used to vend a narrower product.
6. **LOADING MAIN PRODUCT CANDY SHELVES:** The 8-selection (candy type) shelves are loaded similar to the 4-selection shelves except that the bottom of the product sits on the shelf in front of the spiral wire (see Figure 5) that rests on the shelf. These products must also fit prop-

erly in the spiral space; do not force product into spiral. These spirals are removed and installed the same as the large spiral (see Figure 3), except that the front end position is different (approximately 5 o'clock) (see Figure 5) and the front left side of the spiral must be behind the small tab located on the left side of the product space side wall (see Figure 5, Detail A).

7. **PRODUCT SPACERS—8 SELECTION SHELF:** The 8-selection shelves are equipped with a product spacer (see Figure 6) that can be pivoted from the right side of each product space. These spacers should be pivoted out to hold the product upright, but not tight against the product. Leave about 1/8" clearance between the spacer and the product.
8. **PRODUCT PUSHER:** The machine contains enough pushers for you to install a pusher on each candy spiral. This plastic part is designed to push the top of the product forward while it is vending, helping it fall from the shelf. It can also be used with products that have the wrapper end flap on the outside of the package. In this case, the pusher prevents these products from hanging on the spiral by spreading the flap. The pusher is installed approximately 210 degrees from the front end of the spiral with the tab extending forward (see Figure 7).

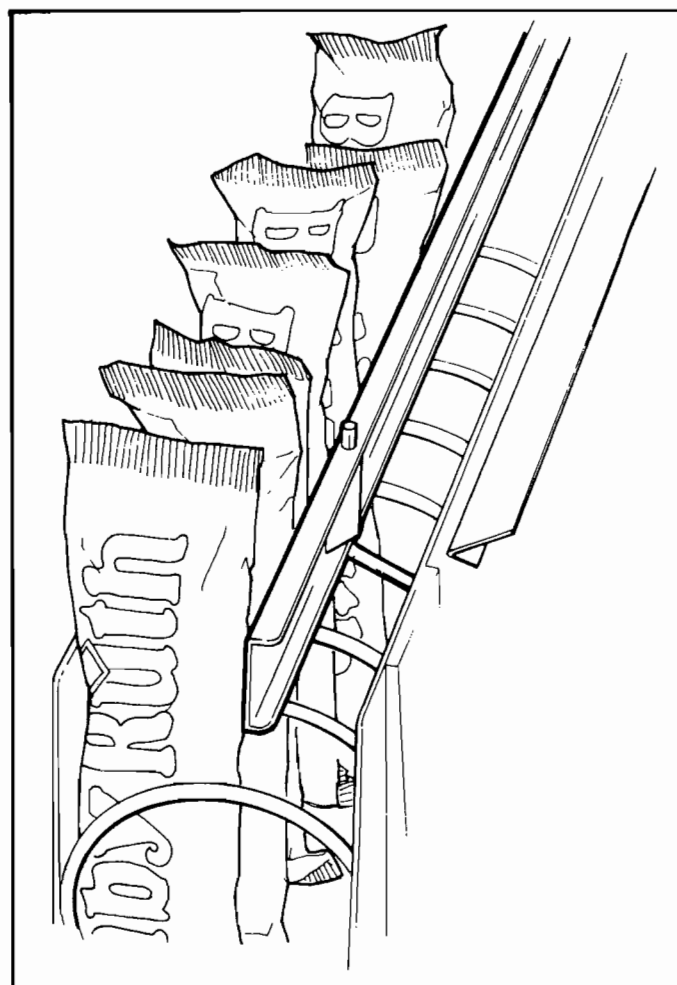

Figure 6. 8 SELECTION SHELF PRODUCT SPACER POSITIONED TO HOLD CANDY UPRIGHT.

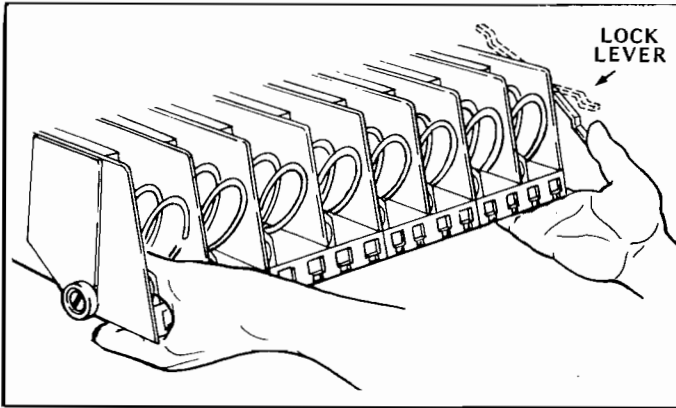

Figure 1. MOVING SHELF TO LOADING POSITION.

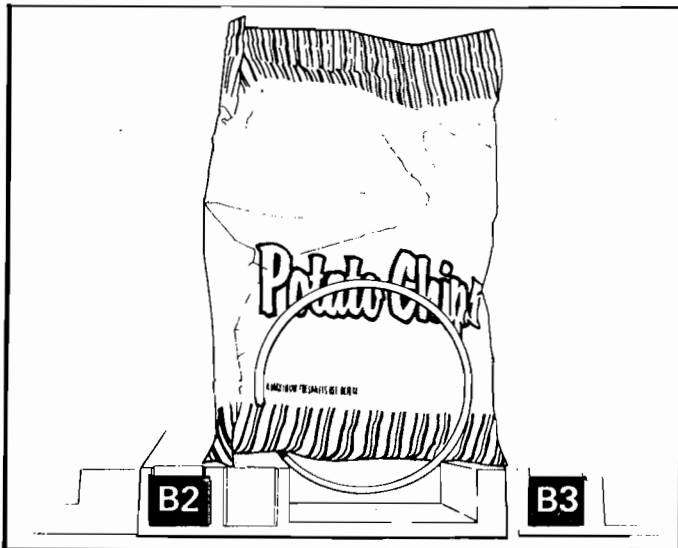

Figure 2. PLACEMENT OF PRODUCT ON MAIN PRODUCT SNACK SHELVES AND FRONT END POSITION OF SPIRAL.

4. REMOVAL OF SPIRAL: Grasp the front of the spiral and turn it clockwise. Lift the spiral up and off of the spiral lock. When replacing a spiral attach it around the tab on the spiral lock and turn the spiral counterclockwise to lock it in place. Be sure the front end of the spiral is positioned properly (with the front end of the spiral pointing downward on the left side) (see Figure 3). The spiral lock is attached between the spiral retainer tabs. Give a light forward pull on front of the spiral to check if it is locked in place.

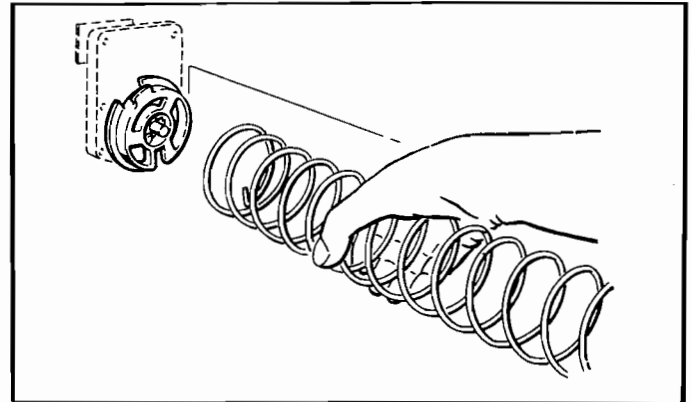

Figure 3. REMOVING AND INSTALLING SPIRAL.

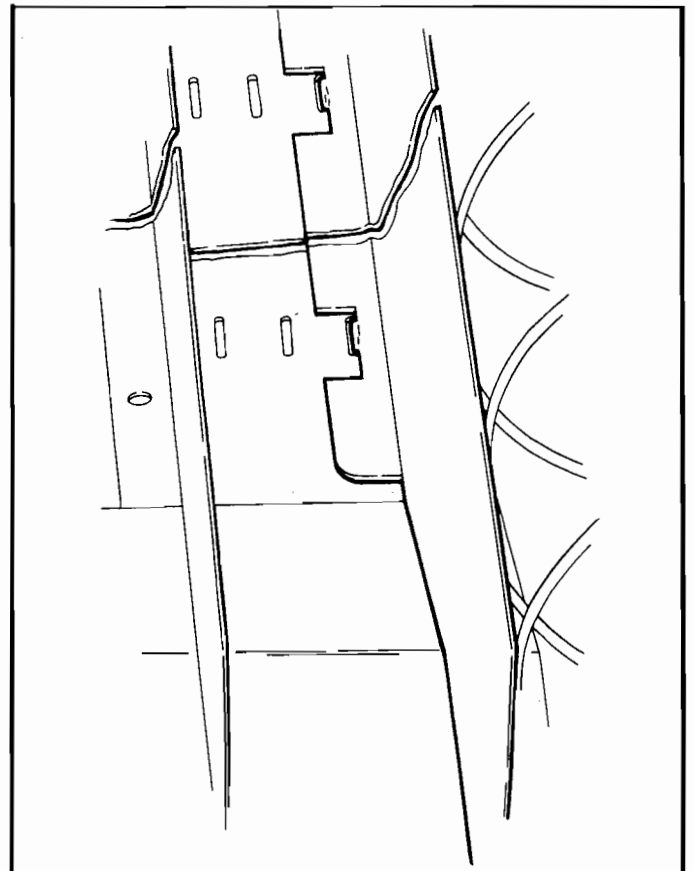

Figure 4. ALIGNMENT OF MOVEABLE PRODUCT SPACERS.

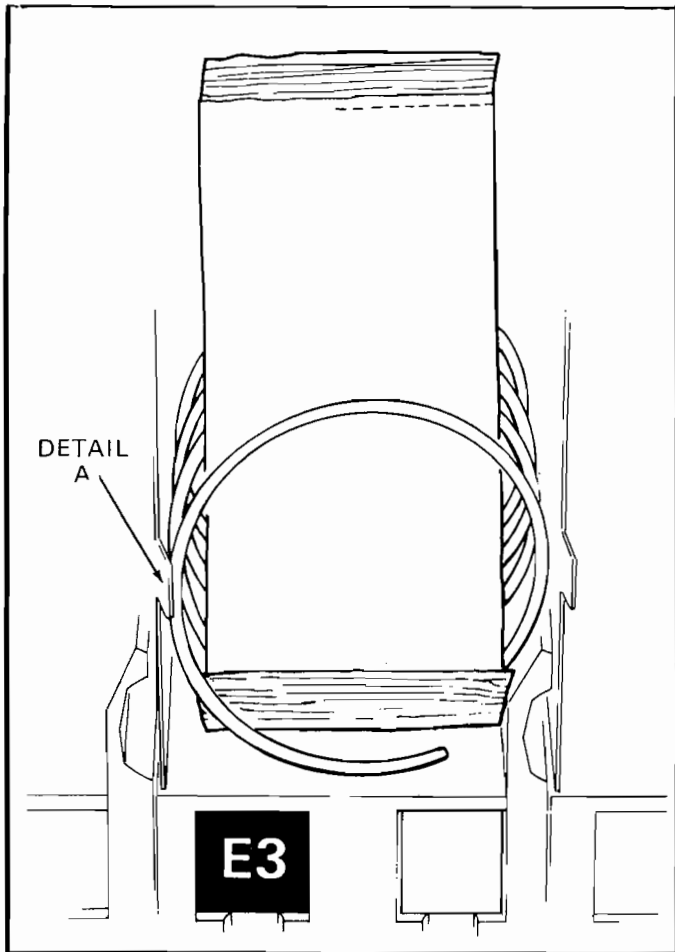

Figure 5. PLACEMENT OF PRODUCT ON MAIN PRODUCT CANDY SHELVES AND FRONT END POSITION OF SPIRAL.

5. **PRODUCT SPACERS—4 SELECTION SHELF:** A product spacer is used to reduce the width of the product area and should be used on any 4-selection snack shelf where the product width is 4½" or less. Spacers should fit within 1/8" of the product but should not fit tight against the product. There are three positions in each snack space where these spacers can be placed. To install the spacer, align the lock ears (on the lower edge of the spacer) with one of the three sets of slots (one front and one rear). (See Figure 4). Push the spacer to the rear to allow the ears to enter the slots, then allow the spacer to move forward. Be sure the ears are in the same set of slots, front and rear. (See Figure 4). Continue loading all spirals adjust with spacers where needed in the top shelf. Return the top shelf to the vend position and following this procedure load the remainder of the large spiral shelves. The shelf divider separating the right (lock side) column from the next column is movable to allow vending of products wider than 5½" in the second column. If this is used the right column must be used to vend a narrower product.
6. **LOADING MAIN PRODUCT CANDY SHELVES:** The 8-selection (candy type) shelves are loaded similar to the 4-selection shelves except that the bottom of the product sits on the shelf in front of the spiral wire (see Figure 5) that rests on the shelf. These products must also fit prop-

erly in the spiral space; do not force product into spiral. These spirals are removed and installed the same as the large spiral (see Figure 3), except that the front end position is different (approximately 5 o'clock) (see Figure 5) and the front left side of the spiral must be behind the small tab located on the left side of the product space side wall (see Figure 5, Detail A).

7. **PRODUCT SPACERS—8 SELECTION SHELF:** The 8-selection shelves are equipped with a product spacer (see Figure 6) that can be pivoted from the right side of each product space. These spacers should be pivoted out to hold the product upright, but not tight against the product. Leave about 1/8" clearance between the spacer and the product.
8. **PRODUCT PUSHER:** The machine contains enough pushers for you to install a pusher on each candy spiral. This plastic part is designed to push the top of the product forward while it is vending, helping it fall from the shelf. It can also be used with products that have the wrapper end flap on the outside of the package. In this case, the pusher prevents these products from hanging on the spiral by spreading the flap. The pusher is installed approximately 210 degrees from the front end of the spiral with the tab extending forward (see Figure 7).

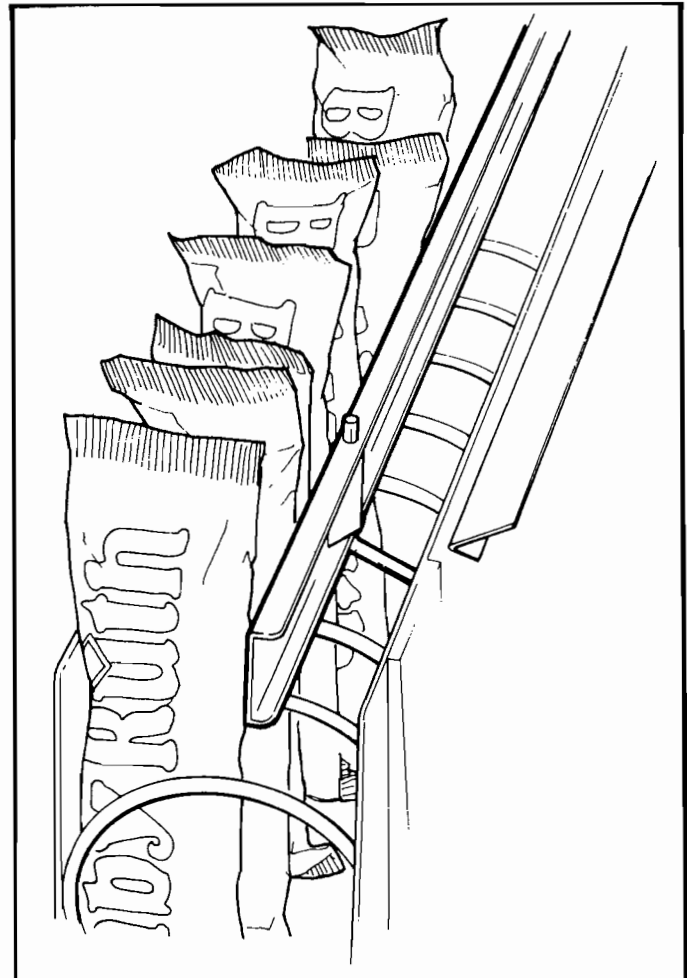

Figure 6. 8 SELECTION SHELF PRODUCT SPACER POSITIONED TO HOLD CANDY UPRIGHT.

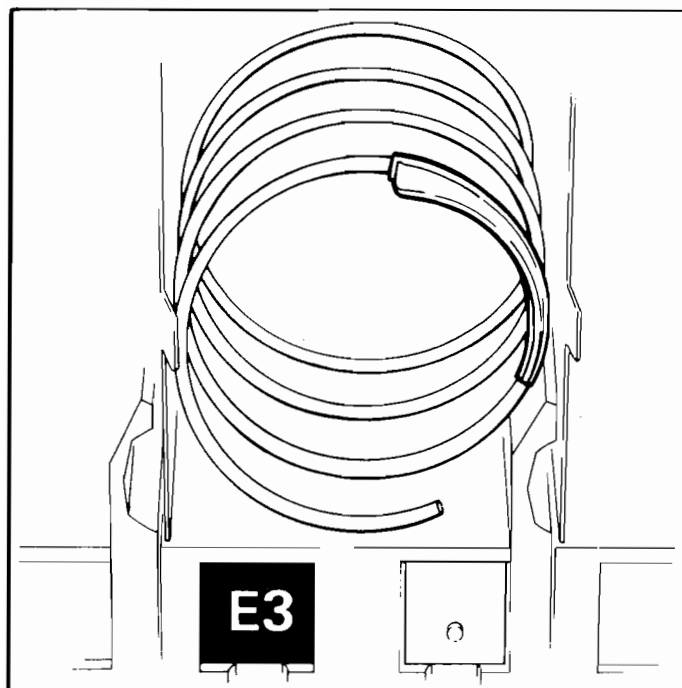

Figure 7. LOCATION OF PRODUCT PUSHER ON SPIRAL.

Locate the pusher in its proper position, hold it against the spiral wire and push the semi-circular part around the spiral wire.

9. **BAGGED ITEMS** in the 8-selection shelves if not loaded properly could be a problem. The sealed edge of the bag may get under the spiral wire causing the product to hang up after it has been vended. It is recommended that the lower edge of these types of product be folded forward and up (see Figure 8) next to the product before inserting into the spiral space. It is also recommended to use an 18 count spiral for bagged items because of the product settling to the bottom of the package.

10. **CIGARETTE VENDING FROM SNACKSHOP 6000.** Cigarettes can be vended from the candy shelves using the (10 capacity) spiral for the soft pack regular, king, 100mm or 120mm packs. The (8 capacity) spiral should be used for (box) packs.

CIGARETTE VENDING FROM SNACKSHOP 6000XL: Cigarettes can be vended from the candy shelves using the (15 capacity) spiral for the soft pack regular, king, 100mm or 120mm packs. The (12 capacity) spiral should be used for (box) packs.

11. **INSTALL PROPER PRICE TABS** into price tab holder for each selection in the main product area. (See figure 9.)

12. **LOADING GUM AND MINT.** The gum and mint shelf is located below the snack shelves (optional). Unlatch the shelf by pulling forward the two metal latches located to the right and left of the shelf and pull forward. The cover can be pushed back to the rear for easy loading. The shelf contains four individual selections.

The first selection on the left contains two fillers for use with thin mints. (Roloids-Certs, etc.). These fillers can be removed for standard mints or gum.

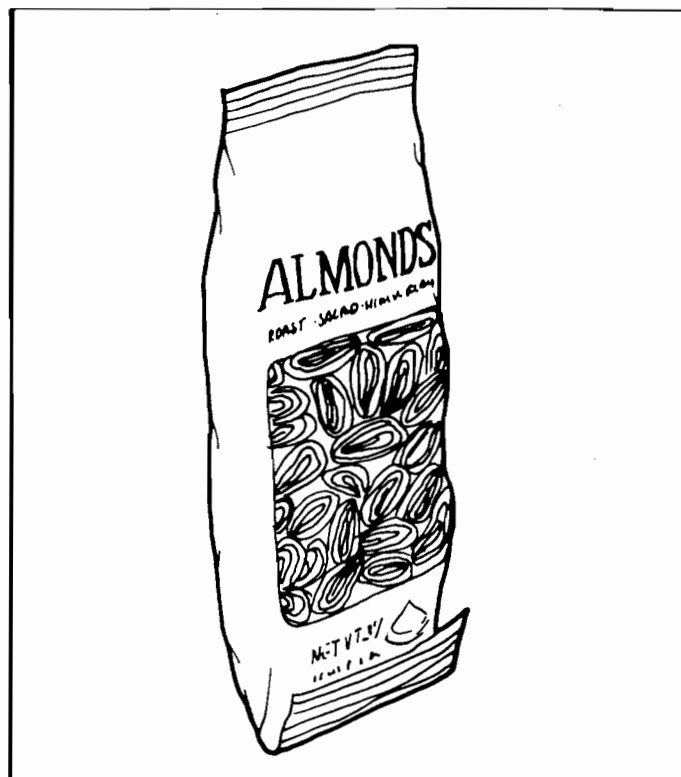

Figure 8. FOLD BAGGED ITEMS BOTTOM EDGE FORWARD AND UP.

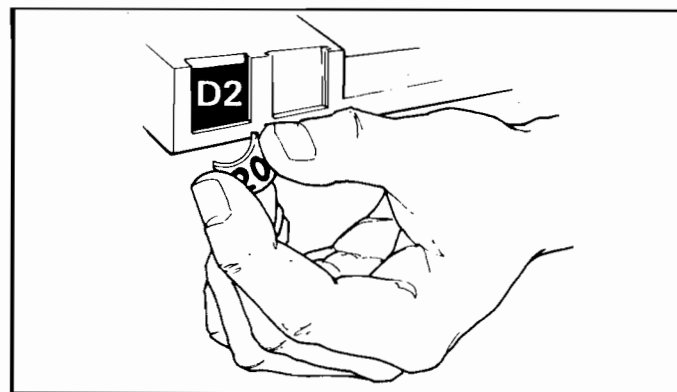

Figure 9. INSTALLING PRICE TABS.

The one selection on the right of the gum and mint shelf has a filler. This selection can be used for standard size gum and mints or the filler may be removed for larger gum and mint products.

Each selection has a display hinge assembly which should be adjusted after the shelf is loaded. To adjust the display hinge, loosen the wing nut and slide the spring hinge of the flipper over the second product and fasten tightly.

INTRODUCTION

The Snackshop 6000 and 6000XL represent a concept in vending. There are no pricing switches, vend relays or individual selection switches. All of the machine functions are managed by a control board located on the sliding panel. The control board operates much like a computer. In addition to controlling normal machine functions the control board has a memory and micro processor for the incorporation of an M.I.S. (Management Information System). M.I.S. was designed to give the operator an accurate and up-to-date view of product movement through the machine (product inventories, cash inventories, service time, etc.). Although M.I.S. is an invaluable tool for the operator, it is not necessary for normal machine operation. The following instructions deal with the functioning and set up operations of the machine with and without the use of M.I.S. Read the instructions from beginning to end to get a complete understanding of all machine functions and the interrelationship of components.

1. POWER SUPPLY

The 115 VAC power cord from the wall outlet comes into the machine and plugs into the left side of the main interlock box located on the bottom hinge side of the machine. The other four connections on the interlock box are for the transformer, lights, fan (optional) and power plug to the control board. All these connections are different so you cannot plug them in wrong. The 115 VAC cord goes to the toggle switch inside the box and then to the circuit breaker. The 115 VAC goes to the transformer which supplies two output voltages 28 VAC (11 & 12) and 12.6 VAC (13 & 14). These voltages then pass through their circuit breakers and all three voltages go up to the control board. The 115 VAC (15 & 16) goes to the power board to the left of the main control board. The 28 VAC and 12.6 VAC goes to the top left plug on the main control board.

The voltage used on the vend motors is 24 VDC. Do not test them with AC voltage and be sure polarity is correct or damage will result.

When removing any component be sure the power is off. Take special care when removing the control board. Do not lay the board on a metal surface.

2. CHANGER

The Snackshop 7000 can use either a Mars (MC-5000) or (TRC-6000) or Coinco (C300E 9234) or (9300L) changer. The changer is to be mounted on the changer mounting bracket located on the sliding panel. Remove the changer hold down screw which has been installed in this bracket for shipment. Hang the changer on the shoulder studs provided. Re-install the hold down screw to lock the changer in place. After securing the changer to the changer mounting bracket, plug the changer into one of the two receptacles located below the control board. The changer plug will determine which receptacle should be used. Be sure the changer cord is clear of the coin return lever operation. Load change into the payout tubes and turn the power switch on.

3. MODE SWITCHES

The mode switches are located on the control board. They allow for control of the following machine functions: Set price mode, check price mode, test vend mode, service mode and set serial number mode (see Figure 10). The

operate mode switch is located by itself on the front face of the sliding panel above the selection panel.

IMPORTANT: When operating the machine in any mode other than the operate mode, the door must be open. The machine is automatically put in the operate mode whenever the door is closed.

NOTE: Before closing the door push the operate button to home any motors which may be out of position.

- A. **Operate Mode**—Normal machine operation featuring total control of coin mechanism operation and accountability.
- B. **Set Price Mode**—Used to program each selection with a price and/or product code.
- C. **Check Price Mode**—Used to check prices and/or product codes of programmed selections.
- D. **Test Vend Mode**—Allows normal machine operation as in the operate mode except management data is recorded separately from data recorded in the operate mode.
- E. **Service Mode**—Indicates the operational condition of all L.E.D. displays and vend motors.
- F. **Product Data Mode** — Machine identification number for M.I.S. accountability.

4. BILL VALIDATOR MODE SWITCH

The switch located just below the "product data mode" switch is for use with a dollar bill acceptor. This dual switch has an on and off position for both price lines.

Price line #1 in the **off** position will accept a dollar bill and if a selection is made will pay back the difference in change. If for some reason the coin return lever is pressed instead of making a selection the customer will receive back that individual dollar.

NOTE: To use the machine as a dollar bill changer at least one selection in the machine should be set for over \$1.00. Example set A6 for a vend price of \$1.10. Therefore, if your machine is used as a dollar bill changer price line #1 should be set to the **off** position. When a dollar is accepted and the coin return lever is pushed it will pay back a dollar in change. Price line #1 in the **on** position will accept a dollar and if the coin return is pushed pay back that individual dollar.

Price #2 in the **off** position will accept a dollar bill and if a selection is made pay back the difference in change. In the **on** position (shoppers mode) after a dollar bill or change is inserted will register that amount on the digital display. When a selection is made the amount on the digital display will deduct the price of that selection. At this time the total cash will be displayed of the amount left of that dollar so that another selection may be made without inserting more money. You, therefore, can push the coin return for your change or make as many selections you want to until the digital display reads below the lowest selling price in the machine, then the rest of the money will be paid back automatically.

NOTE: When using the shoppers mode, there is also a delay time incorporated on the control board. If a customer does not make another selection after a period of 10-15 seconds the changer will pay back automatically.

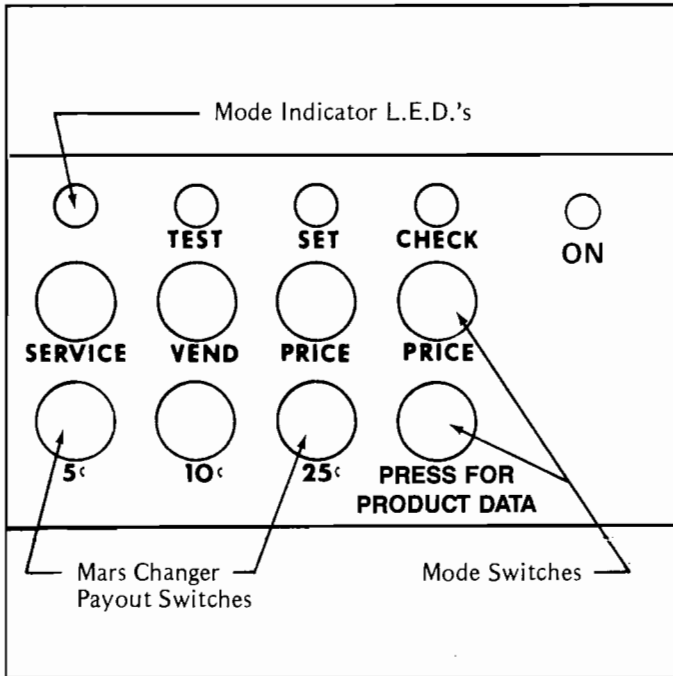

Figure 10. MODE SWITCHES.

5. SELECTION PANEL

The selection panel (Figure 11) on the Snackshop 6000 and 6000XL incorporates the use of a self enclosed membrane switch panel. This eliminates the need for individual switches and wiring. The membrane switch panel is housed in a stainless steel panel with individual buttons protecting the switch face. The casting front also houses the instruction and digital display glass (Figure 12). Included on the instruction glass are three messages for customer instruction when the machine can not complete a vend for an item selected (Figure 12). If this condition occurs, an audible signal is given to the customer and an L.E.D. next to the proper instruction will flash until the customer takes further action.

6. VEND MOTORS

The Snackshop 6000 and 6000XL incorporates the use of high RPM DC Motor. The new DC Motor has an 85% greater starting torque over the Snackshop 400/500 AC Motor, yet weighs only 40% of the AC Motors weight. Due to the new design, the vend motor may no longer be homed by hand. **DO NOT TRY TO TURN THE SPIRALS BY HAND. DAMAGE TO THE MOTOR WILL RESULT.** Any necessary homing will be done by the machine. It is also important to check polarity before applying current to the motor. Two diodes and a capacitor are used to prevent circuit feedback and may have to be checked when trouble shooting motor problems.

7. PRICE SETTING WITHOUT USING M.I.S.

Pricing is done through the selection panel in conjunction with the mode switches.

A. Press the mode switch "set price" button on the control board (Figure 10). The L.E.D. above the set

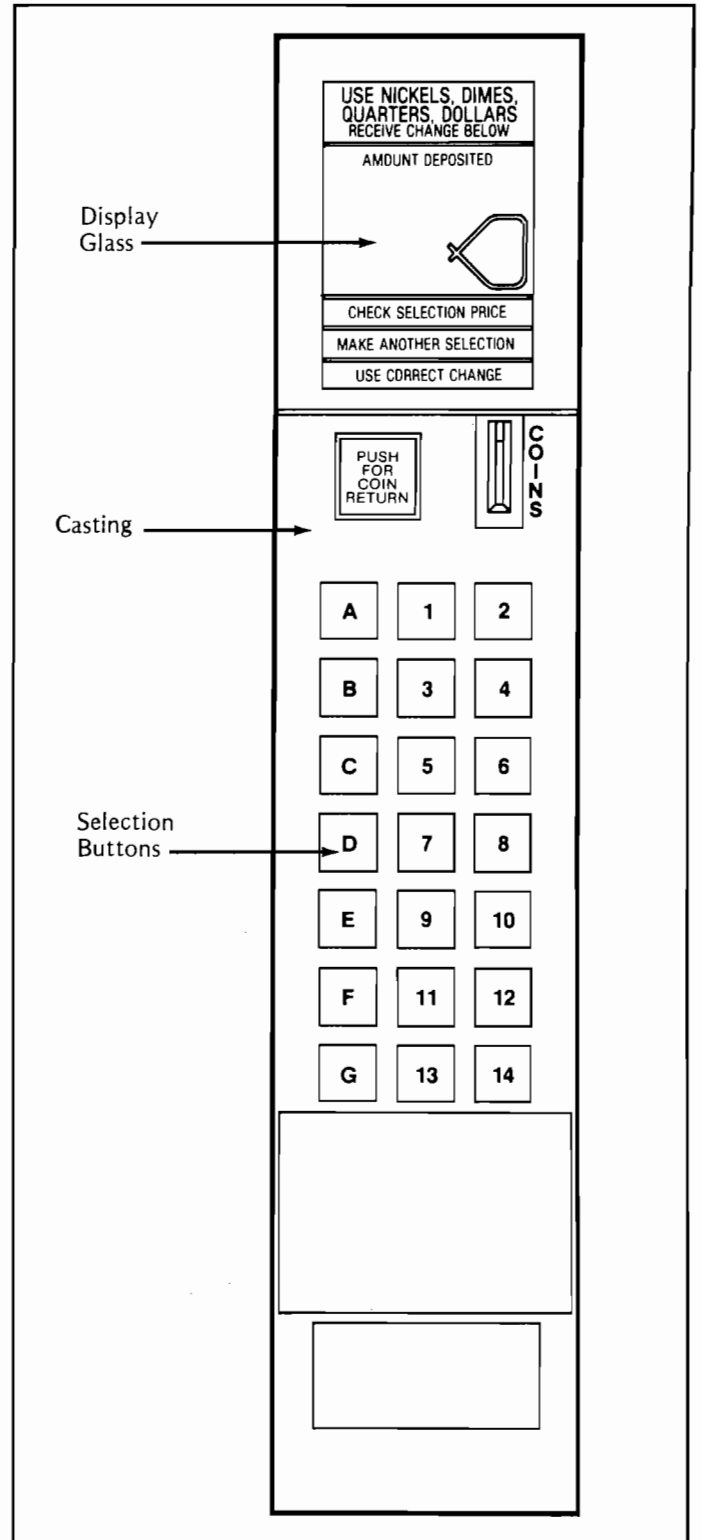

Figure 11. SELECTION PANEL

price will light and the display located on the selection panel will be blank. Any selection programmed at this reading will be removed from the operating program. This would be used when shelves are moved or the number of selections changed to remove those selections not present in the machine from the program.

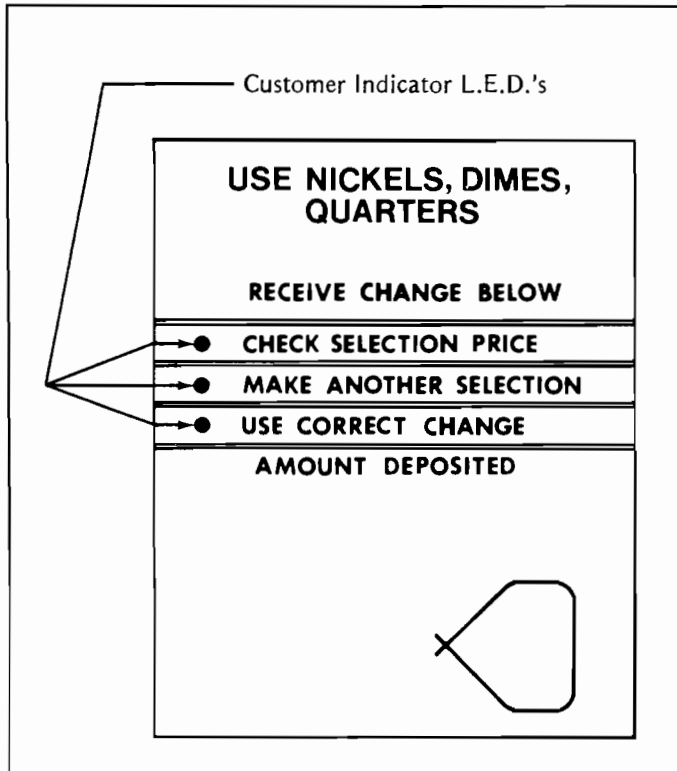

Figure 12. INSTRUCTION AND DIGITAL DISPLAY GLASS.

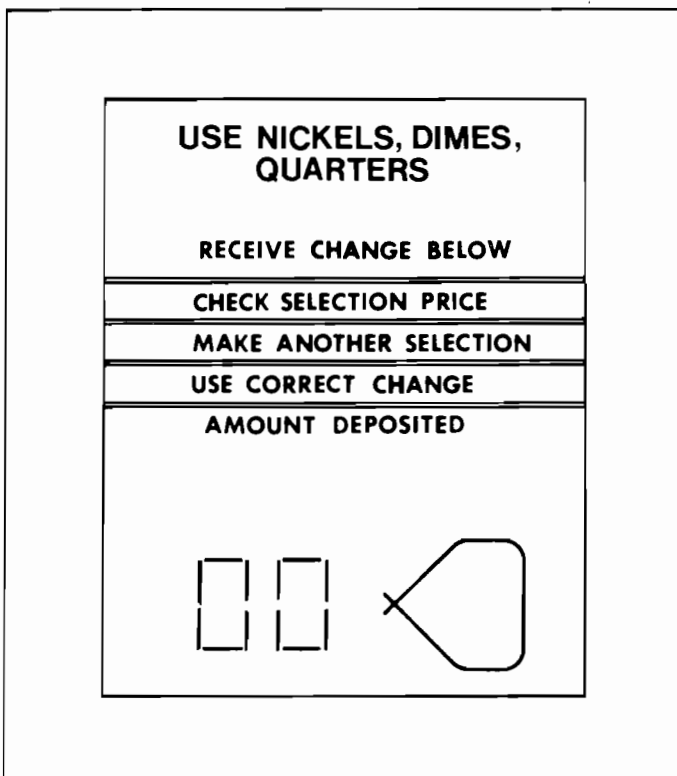

Figure 13.

- B. Press button 11 on the selection panel and the display will show "00.00" (Figure 14) along with three audible beeps will be heard. This is the price display and can be incremented up by pressing button 11 and down by pressing button 12. Increments are 5¢ and each increase will produce one audible beep.

CAUTION: Any selection programmed at "00.00" will free vend.

- C. With the selling price displayed, press first the letter, then the number for each selection to be sold at that price. Increment to your next price and enter those selections. Repeat until all selections have been programmed with their proper price and product code.

8. **PRICE CHECKING WITHOUT USING M.I.S.**

After all prices have been programmed, they should be checked to verify that each selection has been programmed correctly.

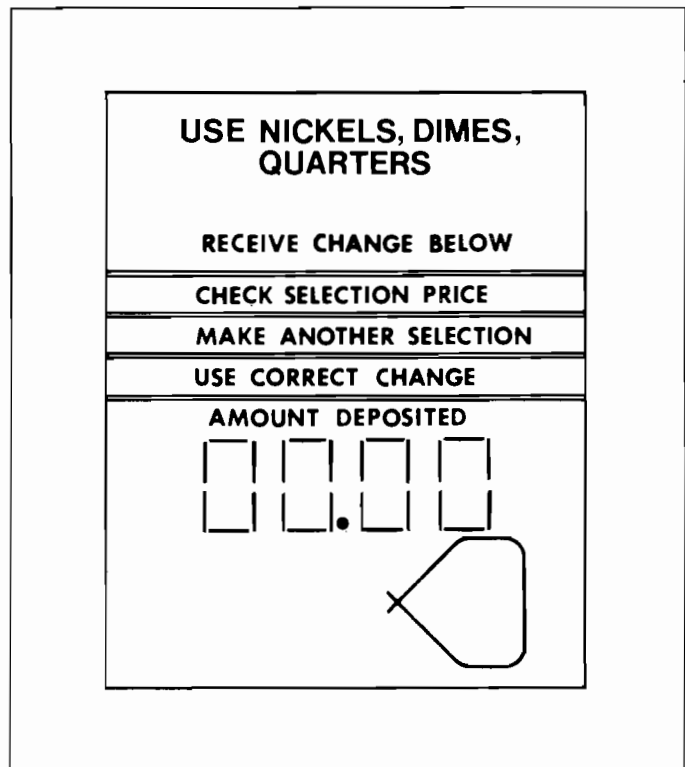

Figure 14.

- A. Press the mode switch "check price" button on the control board (Figure 10). The L.E.D. above the check price button will light and the selection panel display will be blank.
- B. Press the letter and then the number for the first selection to be checked. The price display will show the price that selection is programmed for (Figure 15). Check the displayed price against the price tab on the shelf for that selection.
- C. Continue to check prices until all selections have been checked. Follow "Price Setting Without Using M.I.S." instructions to correct any errors found.

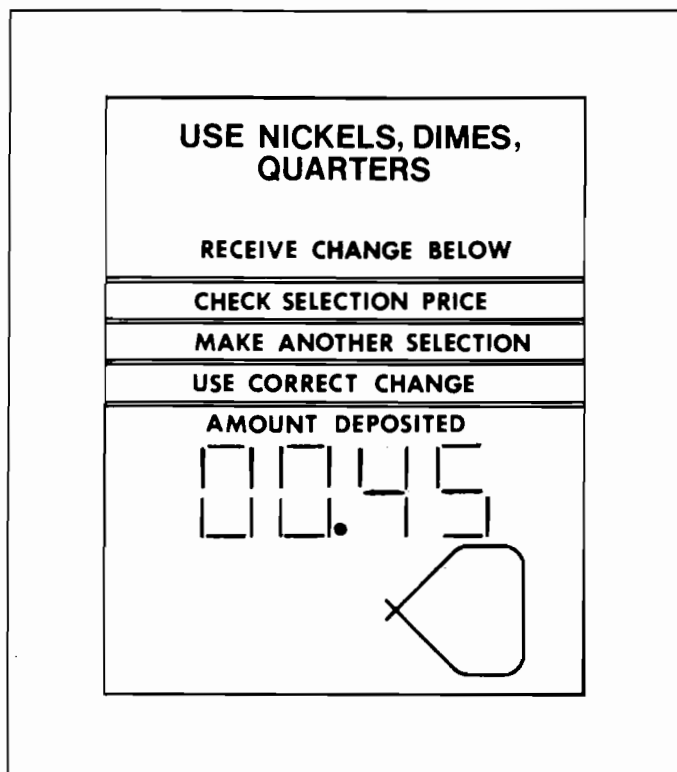

Figure 15. SHOWING A SELECTION PROGRAMMED FOR 45¢

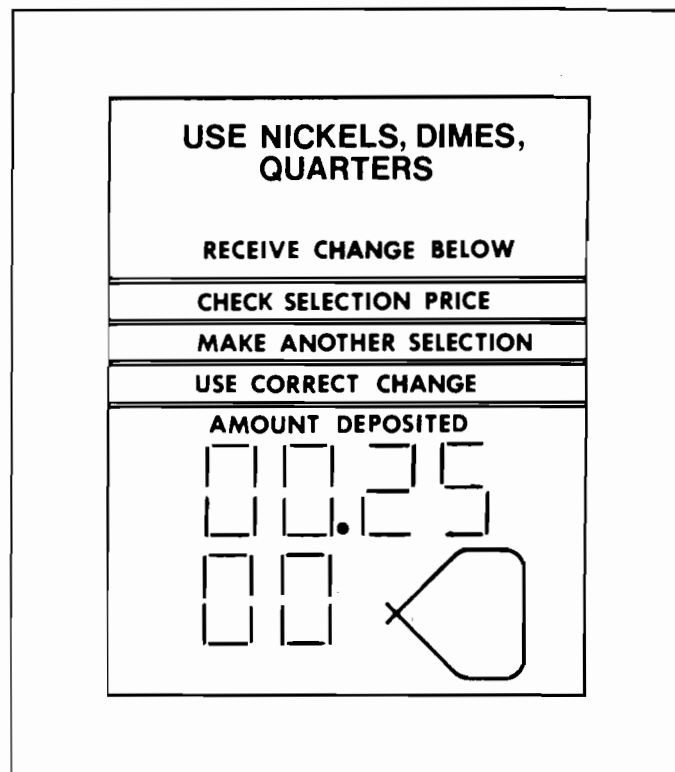

Figure 16.

9. **MANAGEMENT INFORMATION SYSTEM (M.I.S.)**

The Snackshop 6000 and 6000XL are equipped with the data collecting capabilities and the hardware to function as part of the Management Information System. When you are using the M.I.S., the price setting and price checking require the use of a product code. This gives the operator the versatility to use the product codes in any way to best fit his operation.

A product code is a number (00 through 69), used to identify a specific product or group of products. The product code need only be used when M.I.S. is being used. The product code gives the operator total control of individual product sales or product group sales.

The M.I.S. records by product code, the number of vends and total dollar amount vended for each product code programmed. This gives the operator the versatility to program a product code for each selection in the machine or one product code for all selections within the machine.

10. **PRICE SETTING USING M.I.S. AND PRODUCT CODE**

Pricing is done through the selection panel in conjunction with the mode switches.

- A. Press the mode switch "set price" button on the control board (Figure 10). The L.E.D. above the set price button will light and the display located on the selection panel will be blank. Any selection programmed now will be removed from the operating program. This would be done when shelves are moved or the number of selections change (Example: Replacing a four selection shelf for a eight selection shelf.)

Press button 13 and a two digit display "00" will appear on the selection panel which is the product code, (Figure 13). Pressing button 13 the display will change by increments of one, going up. By pressing button 14 the increments will come down by one.

- B. Press button 11 on the selection panel and the display will show "00.00" (Figure 17) along with three audible beeps will be heard. This is the price display and can be incremented up by pressing button 11 and down by pressing button 12. Increments are 5¢ and each increase will produce one audible beep.

CAUTION: Any selection programmed at "00.00" will free vend.

- C. With the product code and selling price displayed, press first the letter, then the number for each selection to be sold at that price and product code. Increment to your next price and/or product code and enter those selections. Repeat until all selections have been programmed with their proper price and product code.

11. **PRICE CHECKING USING M.I.S.**

After all prices and/or product codes have been programmed, they should be checked to insure that each selection has been programmed correctly.

- A. Press the mode switch "check price" button on the control board (Figure 10). The L.E.D. above the check price button will light and the selection panel display will be blank.

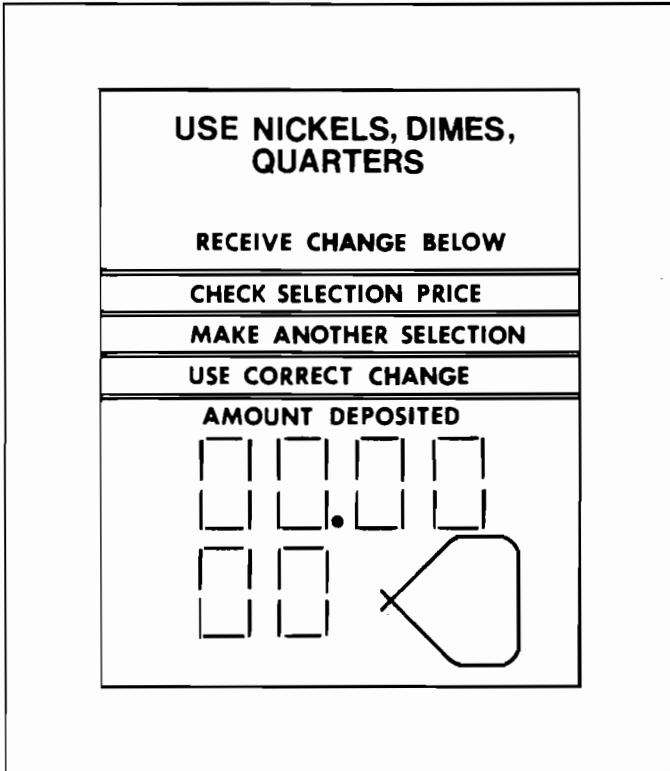

Figure 17.

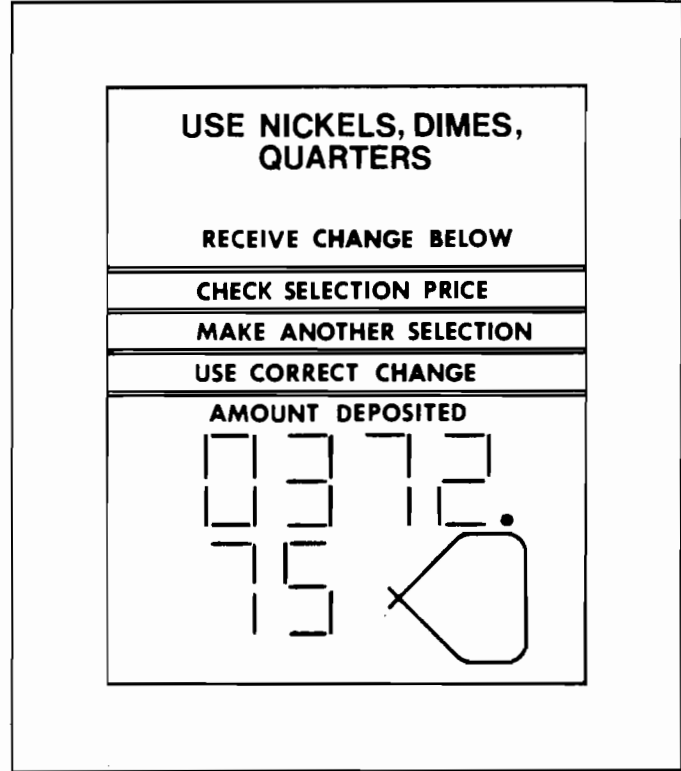

Figure 18. SHOWING \$372.75

- B. Press the letter and then the number for the first selection to be checked. The display will show the price and product code that selection is programmed for (Figure 16). Check the displayed price against the price tab on the shelf for that selection.
 - C. Continue to check prices and product codes until all selections have been checked. Follow "Price Setting Using M.I.S." instructions to correct any errors found.
12. **CASH ACCOUNTABILITY DISPLAY**
 A running total of dollars vended by the machine may be displayed on the selection panel display without the use of the M.I.S. The door on the machine must be closed for cash accountability and inventory reporting functions. The cash accountability may not be changed by anyone and represents an accurate cash meter.
- A. Press the mode switch "check price" button on the control board (Figure 10). The L.E.D. above the check price button will light.
 - B. Press button 14 on the selection panel and the total dollars vended by the machine will be displayed (Figure 18).

INVENTORY REPORTING

- A. Press the (product data) switch on the control board.
- B. To display identification number press selection button C. The number of the machine will be displayed. Once you have recorded the identification number press button C again.

- C. To display number of vends by any product code. For example, enter the product code (63) then the letter G. The number of vends and the product code will be displayed. Repeat until all desired information has been displayed and recorded.
- D. To clear the vends press A, B and G. This will clear the vends and leave the product codes set on their originally set selections.

13. **TEST VEND MODE OPERATION**

The test vend mode was incorporated in the Snackshop 6000 and 6000XL to allow machine servicing and testing without affecting the management data or cash accountability for customer vends and customer dollars received. When M.I.S. is not used, the test vend mode prevents service and test vends from being included in the cash accountability readout. When M.I.S. is being used, the test vend mode records the number of vends and dollar amounts received, in a separate category from that same information which is recorded in the operation mode. This gives the operator total control over all product amounts sold and dollar amounts within the machine.

- A. Press the mode switch "test vend" button on the control board (Figure 10). The L.E.D. above the test vend button will light and the display located on the selection panel will be blank. The machine is now ready to operate exactly under the same conditions as in the operate mode, so you will have to use money for the testing. After all servicing and testing has been made return the machine to the operate mode. The machine is now ready for normal customer usage.

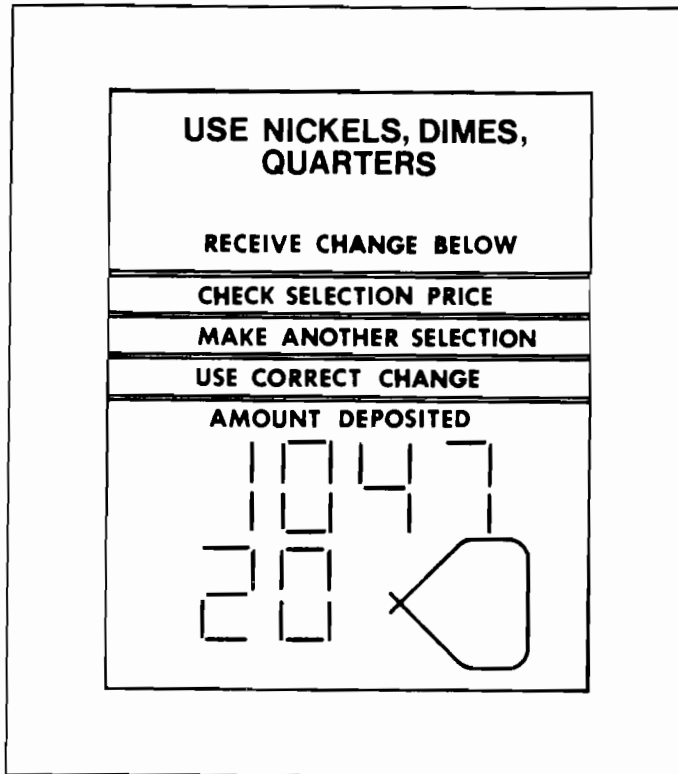

Figure 19. SHOWING A SERIAL NUMBER OF 104720

14. MACHINE IDENTIFICATION NUMBER FOR USE WITH M.I.S.

With using the M.I.S. each machine may or can have an identification number.

- A. Press the "product data" mode switch. Press the letter "C" on the selection panel. The old identification number (if there is one) will be displayed.
- B. Change or enter a new whole number by pressing the panel numerals. Numeral #10 equals 0 (Figure 19).

15. SERVICE DIAGNOSTIC DISPLAY

Incorporated in the Snackshop 6000 and 6000XL series machines is an automatic circuit check. When the machine is engaged in the "operate" mode a scan is made to check the operating condition of all selection motors. If any non-functional motors are in this scan there will be three audible beeps and can now be trouble shooted for corrections.

- A. Press the mode switch "service" button located on the control board (Figure 10). The L.E.D. above the service mode button will light and the selection panel L.E.D.'s will all light (Figure 20). This tells the service person if all L.E.D.'s are in operating condition and that the Control Board is operating.
- B. Press button 14 on the selection panel. If any of the motors are not functioning (jammed, bad switch, bad harness, etc.) the first non-functioning motor in the series will be displayed on the selection panel display (Figure 21).
- C. If a non-functioning motor exists, record the selection on paper and repeat step B. Continue this pro-

cedure until all non-functioning selections have been displayed, recorded and the selection panel display reads all 8's (Figure 20).

- D. If all motors are operational the selection panel display will read all 8's.
- E. Inspect and repair the selections recorded from the service diagnostic display.
- F. After servicing the non-functioning selections return all shelves to a vend position and press the mode switch "operate" button located on the front side of the sliding panel. A delay will occur before the operate L.E.D. will light. This delay is the machine making the automatic circuit scan. At the time the scan is taking place any motors not in the start position automatically are homed. **DO NOT TRY TO TURN THE SPIRALS BY HAND. DAMAGE TO THE MOTOR WILL RESULT.**
- G. To insure that all serviced selections are operational, repeat steps A and B.

16 LIGHTING SYSTEM:

There is only one fluorescent lamp in the Snackshop 6000 and 6000XL. The lamp is located in the top of the door, and lights the main product area and the product sign, if used. The starter is located on the hinge side of the lamp. The balast for the circuit is located on the main interlock box.

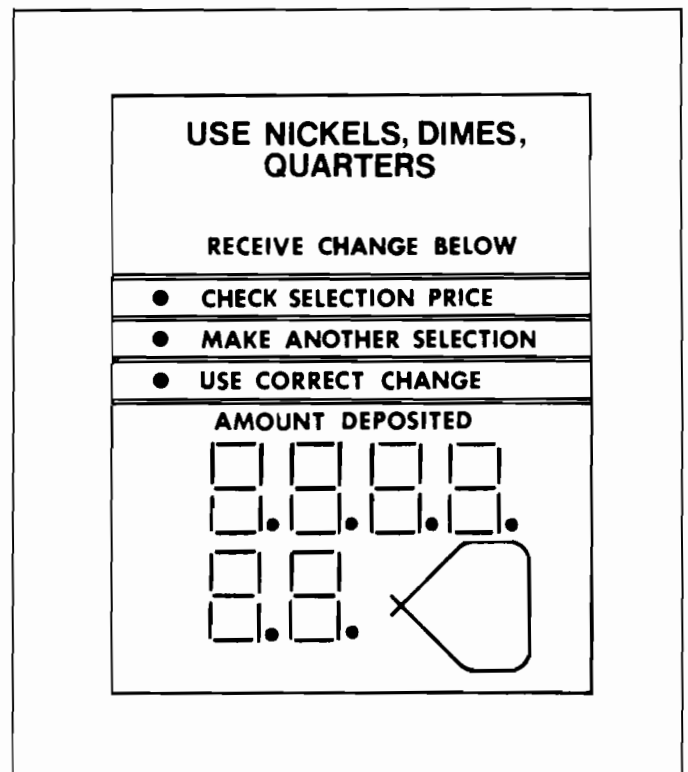

Figure 20.

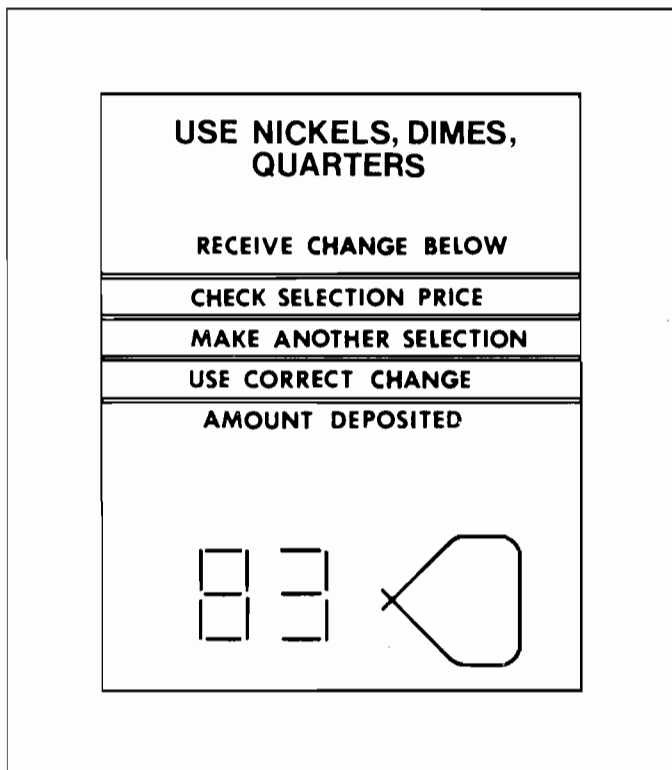

Figure 21. SHOWING SELECTION B3 NOT OPERATING

17 MAIN PRODUCT SHELVES:

There are five or six main product shelves per machine. Each containing either four or eight selections. Each selection has its own motor mounted to the back of the shelf. Every shelf has its own harness and plug for connecting to the remainder of the circuit through the cabinet receptacle, located in the rear center of the cabinet. The motors are the same on either type shelf. It is now possible in the Snackshop 6000 and 6000XL to exchange a four selection shelf with a eight selection shelf or visa versa. You also have the capability to gain 1/2 inch either up or down on the second and/or fifth shelf. To do this the shelf should be removed and the cabinet back harness receptacle lowered or raised. The six rollers on that particular shelf then should be lowered or raised also.

NOTE: When exchanging the shelves, you will not need any parts, but you will have to reprogram the machines for prices and selections.

REMOVAL OF PRODUCT SHELF:

- Lift up and push the lock lever toward the back of cabinet. See Figure 1.
- Pull the shelf to its loading position.
- Grasp shelf in front and rear center. Lift front of shelf up above horizontal and pull shelf forward while lifting.
- To install shelf, reverse above procedure.

18 DELIVERY BIN:

This is located below the display window on the door and is mechanically operated. The linkage on the outside ends of the delivery bin may require occasional lubrication. Should the door become difficult to operate, place a small amount of grease on the arm tracks.

REMOVAL OF DELIVERY BIN:

- Remove the screws from the underside of the delivery bin. These screws fasten into the lower door brace and remove the two screws and brackets at the top of the delivery bin.
- Grasp delivery bin on both sides and lift up and pull back. Should bin be tight, rock it by lifting on one end, then the other.

REPLACEMENT OF DELIVERY BIN:

- Locate lip on front edge of delivery bin over lower edge of opening in door and behind trim. Press down along lip to make sure it is fully engaged between door and trim.
- Install the four screws and two brackets, to secure bin to door.

19. COIN RETURN:

The coin return lever is located on the sliding panel and the coin return linkage is located above the changer, scavenges the slug rejector. Actuation of the coin return lever will clear the rejector of any damaged coins and will also cancel all credit on the changer, returning that amount to the customer.

20. COIN ACCEPTANCE:

A coin or coins (5¢, 10¢ or 25¢ coin) being deposited pass thru the rejector and into their respective coin paths in the changer establishing the credit. The coins then enter either the self-load change tubes on the changer or the cash box. Actuation of the coin return lever prior to making a selection will cancel all credit on the changer and will return the amount of deposit back to the customer.

21. REMOVAL OF GUM AND MINT MOTOR AND/OR EJECTORS:

Disconnect the two wires going to the motor and remove the four screws holding it to the shelf. The components attached to the front base can also be replaced. These consist of the gum and mint shelf front (Price tabs and selection), gum and mint shelf front base, gum and mint display front stop (plastic) and the gum and mint ejector. **NOTE:** Before replacing the gum and mint motor it would be helpful to tap the motor first with the screws. Mount the two components (Items #12 and 13 on Page 36) to the head crank of the gum and mint motor by using the two short screws on the bottom. Then assemble (Items #16 and 17) to the top with the two longer screws. Replace the two wires to the motor and test vend that selection for proper operation.

22. REMOVAL OF GUM AND MINT SHELF:

Below the gum and mint shelf remove the two screws holding the gum and mint receptacle harness bracket

(Page 26, Item 15). Loosen the other two screws on each end of the gum and mint pusher stop strap (Page 36, Item 20) and disengage it from the cabinet. Grasp the shelf and pull the shelf straight out. With the shelf out you can replace the gum and mint pusher (Page 36, Item 31) by removing the screw (Page 36, Item 21). Reverse the procedure to replace the shelf. Pay special attention when you put the gum and mint pusher stop strap back on that all the gum and mint pushers have spring tension and are behind the strap.

23. REMOVAL OF CONTROL PANEL:

In some locations, due to the size of this machine it is not possible to move the fully assembled machine through doors or narrow hallways. The control panel may be pushed back inside the cabinet by removing the control stop (Item 23, Page 26) or the entire control panel can be removed from the machine by using the following procedure:

- A. Pull panel to its full position.
- B. Remove the control board cover and power board cover.
- C. Disconnect main cabinet harness and power plugs off the control board.
- D. Remove the wrap harness screw and ground screw to the control panel.
- E. Remove the top stop bracket located on the upper side of roller channel assembly.
- F. Grasp panel to support its weight and pull forward and lift upward. Be careful that the roller channel does not fall off the panel.

REPLACEMENT OF CONTROL PANEL:

- A. Engage the lower edge of the panel to the lower guide channel.
- B. Guide the roller channel onto the upper track and lift and push panel and channel into the cabinet.
- C. Reinstall stop bracket. This bracket must be installed in back of the channel in top of the cabinet, as this bracket is what stops the sliding panel in its forward position.
- D. Replace the cabinet and plug harnesses to the control board.
- E. Replace the tie wrap harness and ground screws.
- F. Replace the control board cover.
- G. Push panel back into the cabinet.

cleaning

The Snackshop 6000 and 6000XL will do the best merchandising job for you if it is kept clean. The display window can be cleaned with any good glass cleaner. The exterior and interior surfaces should be cleaned with warm water and mild detergent. Rinse thoroughly and dry all surfaces.

CAUTION:

Do not use any cleaners containing silicon as this could cause electrical failures.

The main product shelves can be best cleaned with the spirals and product spacers removed. Refer to page 7 for removal of spirals and page 8 for removal of the product spacer. We do have cleaner available that we feel is superior to any other

cleaner we have tried in the past. The cleaner (Part #460386) comes in a 20 ounce aerosol can and is used by spraying a good coating over the surface to be cleaned, then letting the cleaner set for 3 to 3½ minutes and wiping it off. After the shelf has been cleaned a neutralizer (Part #460387) should be sprayed on and wiped off. The neutralizer will have to be transferred to a smaller bottle with a sprayer. There are openings in each end of the delivery bin at the back for cleaning out dirt.

Clean the acceptor on the changer frequently as accumulated dirt in this area can cause coins to hang or not be accepted. Follow recommended cleaning procedures as described by the manufacturer.

optional equipment

1. VENTILATING FAN: (Kit #750102)

The ventilating fan operates on 115 volts and keeps a steady flow of fresh air moving through the vendor cabinet. All the vendors are wired with a plug for the fan on the left side of the interlock box. Installation instructions are sent with each kit.

2. BASE KITS:

Base kits are available to make the vendor compatible with other manufacturers.

3. GUM-AND-MINT:

Gum-and-Mint units are available as an option with Snackshop 6000 and 6000XL vendors.

For information pertaining to loading or servicing gum-and-mint unit, refer to this service manual for loading instructions and for service instructions.

4. SOUP DISPENSER 6000. (Kit 750083-1)

A canned soup dispenser is available as an option for use in the four selection snack shelves. The dispenser is easy to install and holds up to seven cans in the unit.

SOUP DISPENSER 6000XL. (Kit 750083)

A canned soup dispenser is available as an option for use in the five selection snack shelves. The dispenser is easy to install and holds up to nine cans in the unit.

5. DOLLAR BILL VALIDATORS:

There are two kinds of validators available Ardac (Part #420147-4) and Mars (Part #420147). The validators take but a few minutes to install and may also be purchased through the manufacturer of that unit.

6. SPECIAL SPIRALS (6000XL ONLY):

Special candy spirals are available for use in the four (4) selection snack shelves on 6000XL machines only. For the sake of identification, the back end of these spirals are colored RED and should never be used in the eight (8) selection candy shelves.

These spirals allow vending products that are too wide for the standard candy columns but may be too thin for the regular snack spirals. A product pusher and spacer should be used where required. Part numbers for these special spirals are as follows:

400139	12 space special spiral
400140	15 space special spiral
400141	18 space special spiral
400142	24 space special spiral
400143	30 space special spiral

NOTE: The difference between the standard candy spiral and the special candy spiral used in the wide snack columns is in the overall length of the spiral. The special spiral is shorter than the standard candy spirals.

CAUTION: Do not attempt to use the special candy spirals in an eight (8) selection shelf.

bill validator – instructions for installation

The Service Envelope in the bottom of the machine contains different mounting brackets and decals for use with and without bill validators.

The machine, if ordered with a dollar bill validator, will already have the unit mounted (Mars or Ardac). If for some reason you wanted to exchange units or not use a validator at all, we have provided these brackets and decals.

MARS: When installing a Mars Validator use the dollar decal and brackets shown on the right. It would be easier to install the brackets to the panel with the hex nuts and use the dollar “empty” light as a guide. Take the four screws and mount the Mars Validator to the bracket with the identification label facing out. The harness then can be plugged into the bottom of the validator, to the stacker and plugged into the bottom pins of the power board, and to the bottom left side pins of the main Control Board.

ARDAC: When installing an Ardac Validator use the decal and plate shown on the right. Using the dollar “empty” light as a guide mount the plate with the four hex nuts. Mount the validator to the place with four more hex nuts. Insert the stacker in the validator (making sure it is locked into place). Mount the control box onto the studs provided to the left of the coin cup chute and fasten it on to the panel with two screws. The 15 pin plug on the left side of the control box goes over to either one of the stacker plugs. The 15 pin plug on top of the control box goes over to either one of the plugs on the validator. The 120 volt plug on the top of the control box goes to the bottom two right pins on the power board. The 21 pin plug goes up to the bottom left pins of the main Control Board.

ROWE: When installing a Rowe Validator use the decal to the right and the two silver plates provided in the service envelope. Attach the “use coin only” light harness into the small silver bracket. Mount the small silver bracket (part #201517) to the front panel with two hex nuts using the “use coin only” hole as a guide.

Mount the lower silver bracket (part #201518) with two other hex nuts. Tap two screws half way into the top of this. Then guide the Validator onto these screws and fasten. Tighten down the upper part of the Validator to the top bracket.

Mount the control box vertically on the sliding panel, just to the left of the changer with 4 screws. Plug the harness into the bottom of the Validator. Run the other plug under the coin cup chute and plug it into the top transport position on the control box. Then fasten the green wire to the sliding panel. Plug the second harness into the bottom (interface) on the control box. Install the two wire (white and black) plug to the bottom right pins on the main power board. The five wire plug goes to the bottom left pins on the main control board. Secure and tuck all loose harnessing away from any possibility of damage.

NO VALIDATOR: Use the decal and bracket as shown. The short solid bracket is used to fill the hole on the control panel. Insert this bracket and hold it against the panel with the Ardac mounting plate.

Bronze
(Part #201433)

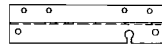
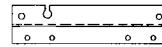

(Part #201463)

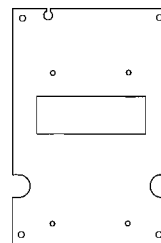

Silver
(Part #201517)

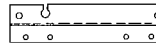

(Part #201518)

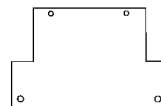

(Part #201418)

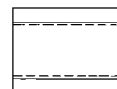

(Part #460361)

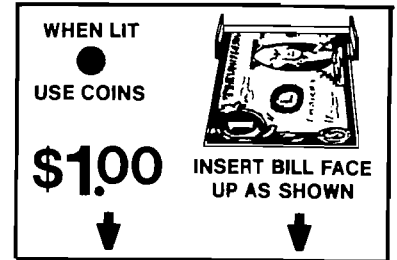

(Part #460358)

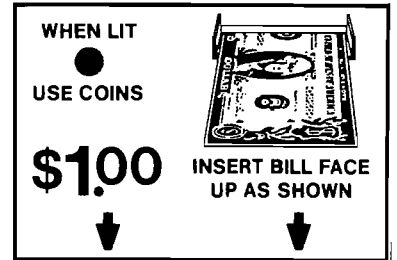

(Part #460361)

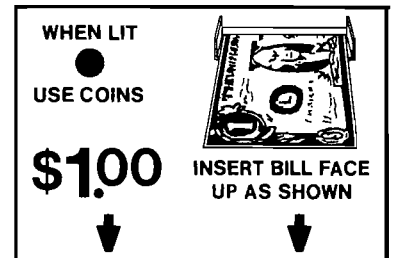

(Part #460359)

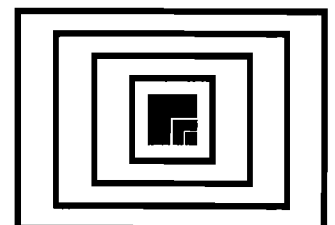

door – outside front

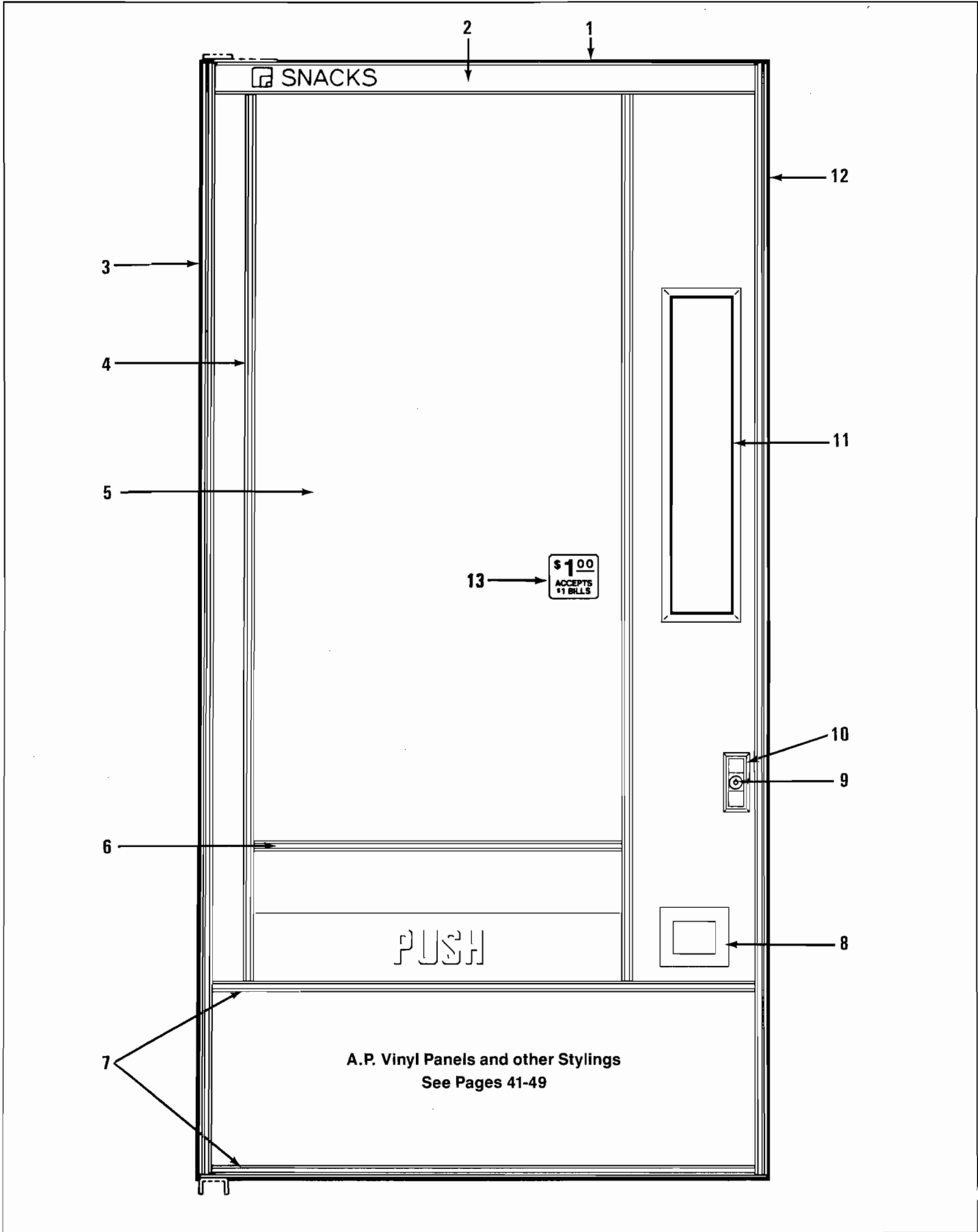

Item No.	Part No.	Description
1	340044-6	Top, Trim. For use w/Vinyl Insert.
2	440258-5	Insert, Top Trim, Snacks.
3	340057	Trim, Outside Vertical (Right or Left).
4	340058-2	Trim, Inside Vertical (Right or Left).
5	750141-1	Window, Front. (44-5/8 x 21-9/16 x 1/8). NOTE Replacement Glass Must Be Hard Tempered or Lexan Only.
6	340058-1	Trim, Inside Horizontal.
7	340055-6	Trim, Inside Horizontal.
8	440296	Coin Cup Trim. Black. Plastic.
9	420071	Ace Lock w/2 Keys.
	420071-1	Ace Lock w/1 Key.
	420071-2	Ace Lock w/o Key.
10	660319-1	Lock Handle Assembly. W/Lock Arm and Nut.
11	320055	Trim, Control Ring.
12	600429	Door Only. Specify Color.
13	460375	Dollar Decal.

door – inside front

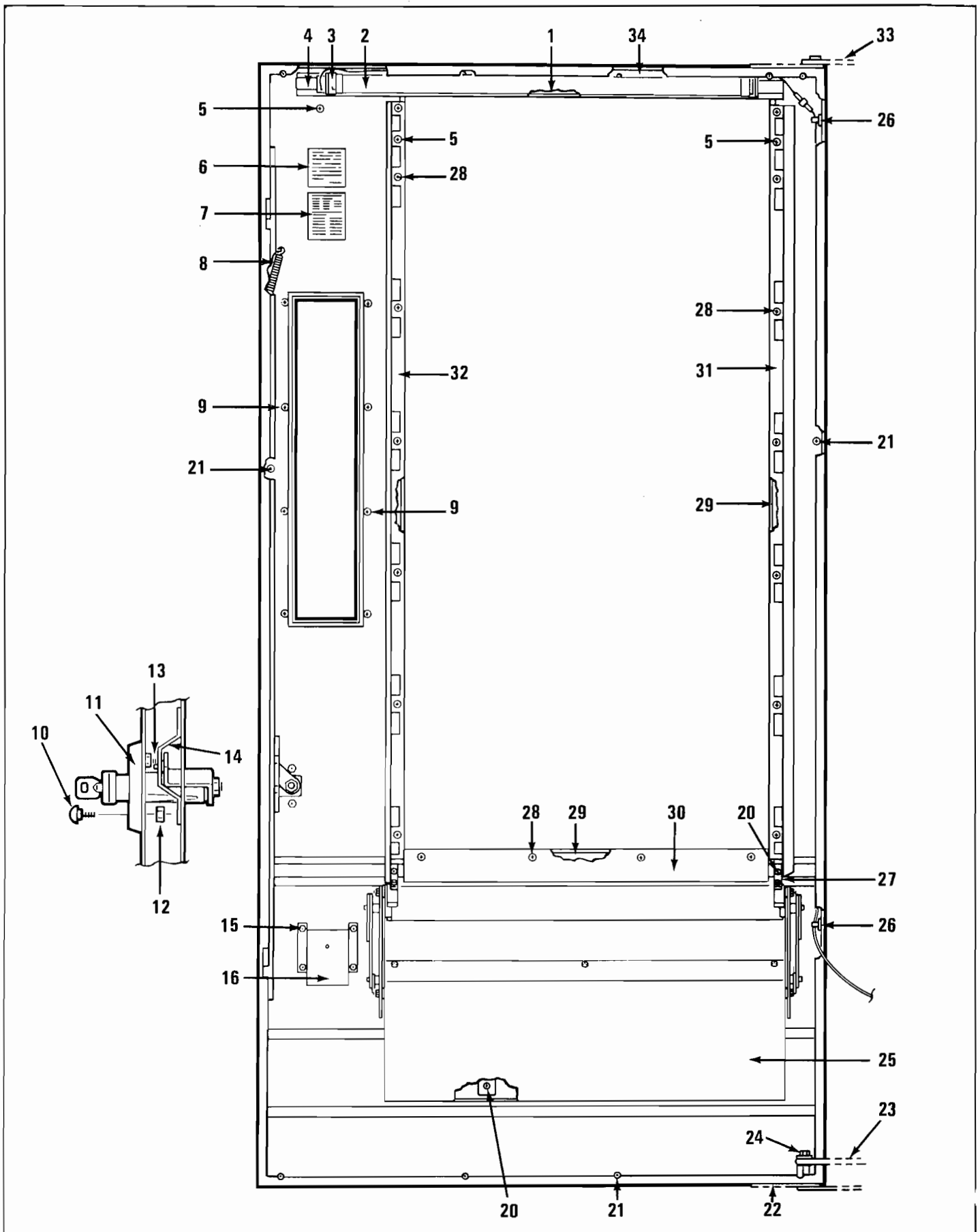

Item No.	Part No.	Description
1	460041-1	Insulation, Foam (1/4 x 1/4 x 50").
2	380022-5	Lamp, Fluorescent (F18T8-CW-K24)
3	380047	Socket, Fluorescent Lamp Only.
	680138	Assembly Complete. Lamp Harness.
4	380023	Starter. FS-25.
	380023-4	Starter. FS-11, Export Only.
5	201-6R7	Screw Rd. Hd. Phillips Type B (6-18 x 7/16).
6	460308	Label FCC.
7	460085	Decal, Patent.
8	400112	Spring, Locking Bar.
9	276-6R6	Screw, Pan Hd. Self-Tap (6-32 x 3/8).
10	118-10-8	Carriage Bolt (#10-24 x 1/2).
11	660319-1	Assembly Complete. Lock Handle. W/Lock Arm and Nut.
	420146	Lock Handle Only.
12	404-10	Nut, Hex (10-24).
13	640123	Lock Arm Only.
14	600432	Locking Bar only.
15	18443	Nut, Hex Hd. (8-32).
16	201155	Coin Return Cup.
	201156	Coin Return Cup Door.
20	217-8R10	Screw, Pan Hd. Phillips (#8 x 5/8).

Item No.	Part No.	Description
21	200-6R6	Screw, Rd. Hd. Phillips Type A (6-18 x 3/8).
22	640012	Lower Hinge.
	420003	Screw, Flat Hd. (1/4 - 20 x 3/4).
23	400090	Door Stop.
24	300151	Nut, Special.
	420010-10	Washer.
	114-41-8	Screw, Hex Hd. Mach. (1/4-20 x 1/2).
25	660310-1	Assembly, Delivery Bin Complete. (See Page 37 for Itemized Parts)
26	420097	Cord Clip.
27	200906	Delivery Bin Anchor Strap.
28	201-6R12	Screw, Rd. Hd. Phillips Type B (6-20 x 3/4).
29	460436	Insulation, Rubber. Black. (Order number of inches needed)
30	201385	Bottom Window Clamp.
31	201381-3	Window Side Shield (clamp) Pivot. 6000XL & 6000.
32	201381-2	Window Side Shield (clamp) Lock. 6000XL & 6000.
33	640120	Assembly, Upper Hinge.
	420003-1	Screw, Flat Hd. (1/4-20 x 1/2).
34	440084	Light Reflector.

cabinet

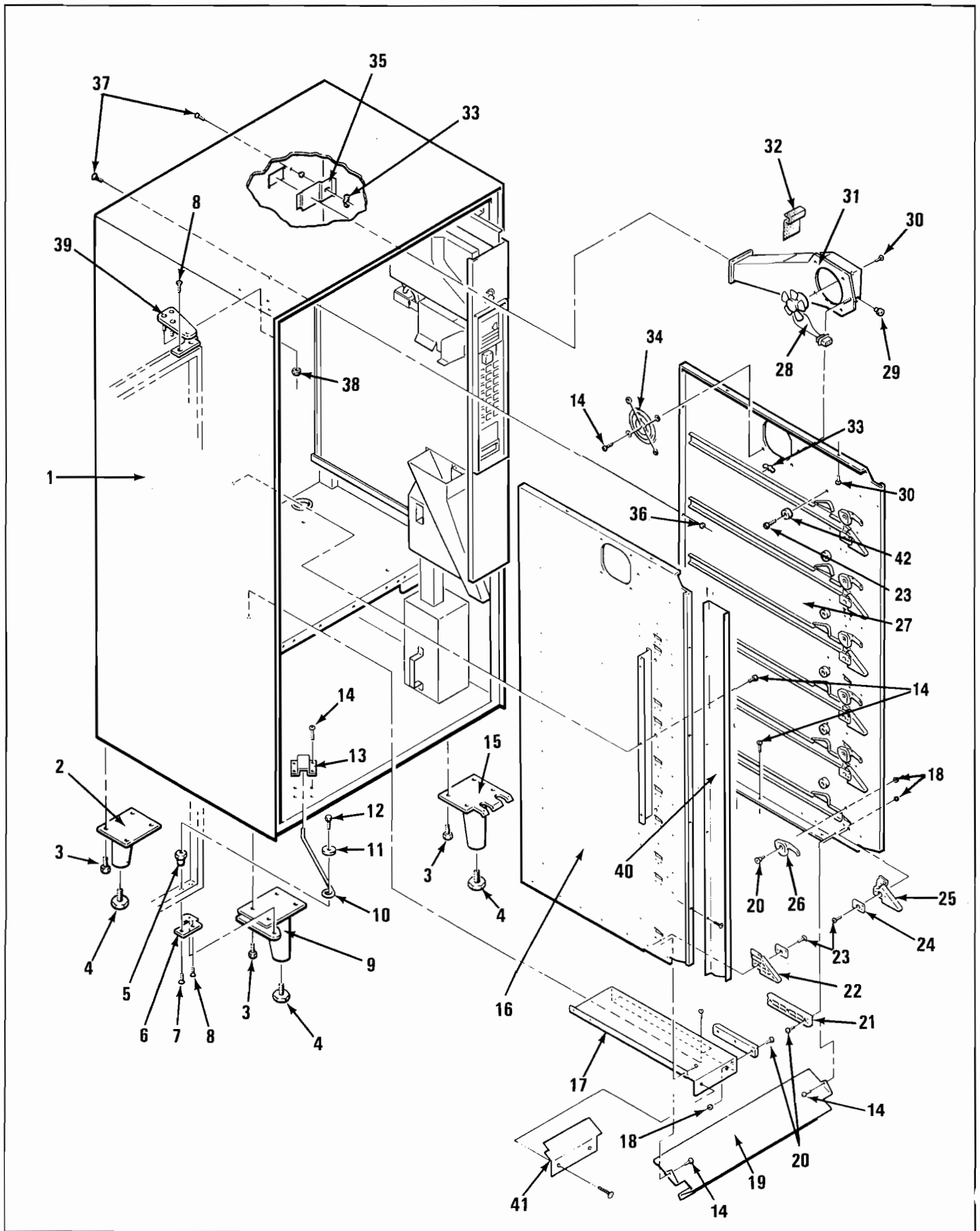

Item No.	Part No.	Description
1	750101-2	Cabinet Assembly, w/Legs-6000. Specify Color.
	750101-3	Cabinet Assembly, w/Legs-6000XL Specify Color.
2	600195	Leg Assembly. Rear.
3	114-51-12	Screw, Hex hd. Mach. (5/16-18 x 3/4)
4	300103	Leg Leveler.
5	300151	Nut, Special. Door Stop Anchor.
6	640012	Pivot, Lower Hinge.
7	420003	Screw, Flat Hd. Allen (1/4-20 x 3/4).
8	420003-1	Screw, Flat Hd. Allen (1/4-20 x 1/2).
9	600196-3	Leg, Front. Hinge Side.
10	400090	Door Stop.
11	420010-10	Washer.
12	114-41-8	Screw, Hex Hd. Mach. (1/4-20 x 1/2).
13	200940	Door Stop Bracket.
14	276-8R6	Screw, Pan Hd. Self-Tap (8-32 x 3/8).
15	600197	Leg Assembly. Front Lock Side.
16	660312-8	Assembly, Complete. Left Side Panel. 5 Shelf-6000.
	660312-9	Assembly, Complete. Left Side Panel. 5 Shelf-6000XL
	600417-4	Panel only. Left Side. 5 Shelf-6000.
	600417-2	Panel only. Left Side. 5 Shelf-6000XL.
	660312-10	Assembly Complete. Left Side Panel. 6 Shelf-6000.
	660312-11	Assembly, Complete. Left Side Panel. 6 Shelf-6000XL.
	600418-4	Panel only. Left Side. 6 Shelf-6000.
	600418-2	Panel only. Left Side. 6 Shelf-6000XL.
17	201450-1	Filler, G & M Pivot Side.
18	437-41	Nut, Keps (1/4-28).
19	201386-1	G & M Filler Panel. (Use without G&M Shelf).

Item No.	Part No.	Description
20	300137	Screw, Shelf Roller.
21	440278	G&M Tray Slide.
22	440264	Front Roller Guide, Left Side.
23	276-8R12	Screw, Pan Hd. Phillips (8-32 x 3/4).
24	201389	Roller Retainer.
25	440263	Front Roller Guide, Right Side.
26	440161	Shelf Lock.
27	660311-5	Assembly Complete. Right Side Panel. 5 Shelf - 6000XL
	660311-8	Assembly Complete. Right Side Panel. 5 Shelf - 6000
	660311-6	Assembly Complete. Right Side Panel. 6 Shelf - 6000XL
	660311-9	Assembly Complete. Right Side Panel. 6 Shelf - 6000
	600415	Panel only. Right Side. 5 Shelf-6000XL
	600415-2	Panel only. Right Side. 5 Shelf-6000.
	600416	Panel only. Right Side. 6 Shelf-6000XL
	600416-3	Panel only. Right Side. 6 Shelf-6000.
28	750102	Kit, Assembly, Complete.
	680313-2	Assembly, Fan Complete Only.
	750102-1	Kit, Complete Ventilating Fan, Export Only.
	680313-1	Assembly Fan Complete Only, Export.
	420040-6	Snap Bushing.
29	277-10 R8	Screw, Pan Hd. Self-Tap (8-32 x 1/2).
30	640118	Assembly, Fan Chute only.
31	201176	Fan Screen.
32	420023	Wing Nut (8-32).
33	380215	Fan, Finger Guard.
34	201382	Fan Hole Cover.
35	404-8	Nut, Hex Hd. (8-32).
36	335-8R6	Screw, Pan Hd. Tap-Tite Phillips. (8-32 x 3/8).
37	438-41	Nut, Keps (1/4-20).
38	640120	Upper Hinge Assembly.
39	201383	Panel, Left Side Extension-6000XL Only.
40	201550	Plate, G&M Filler. Deflector.
41	440306	Shelf Guide Button.

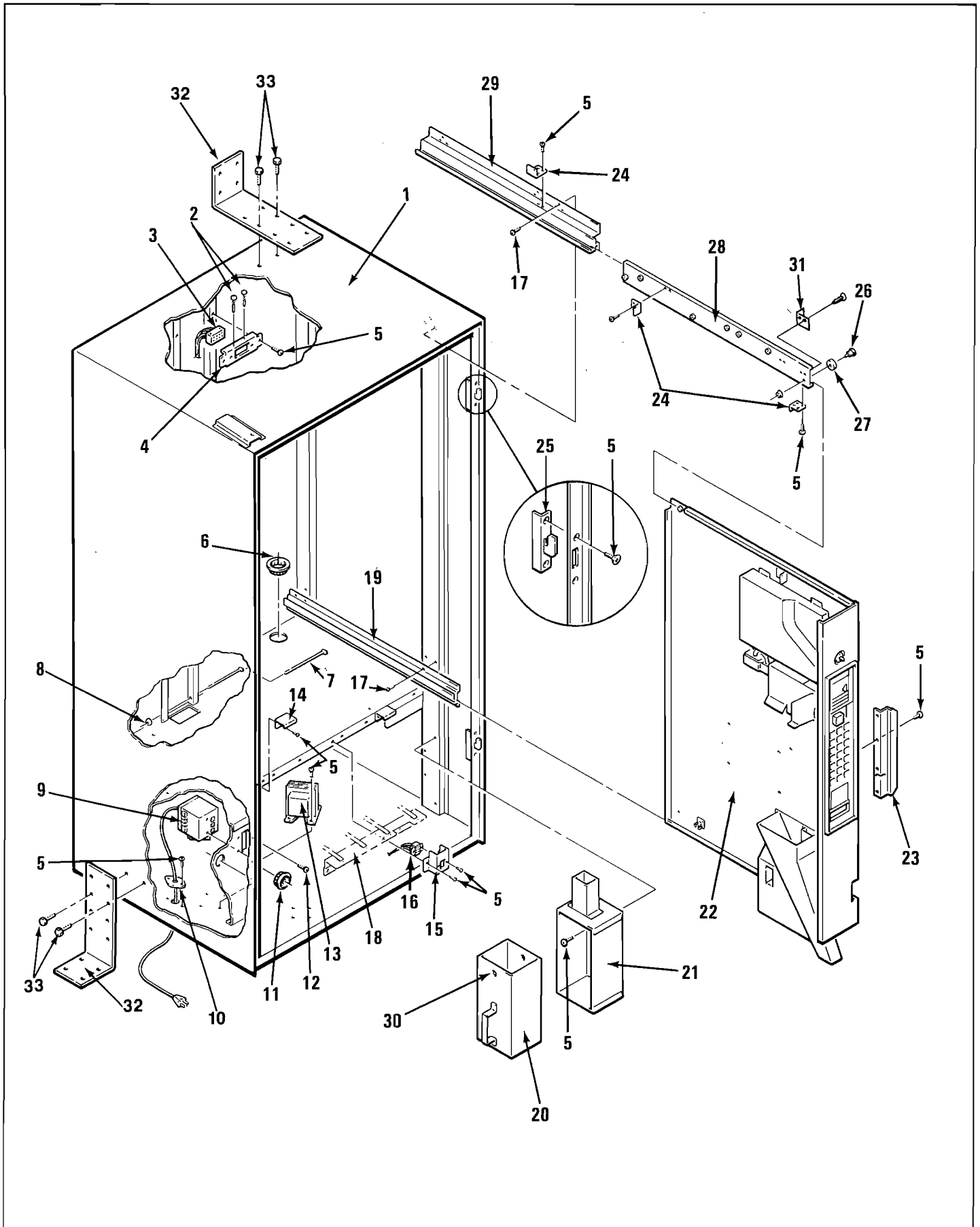

Item No.	Part No.	Description
1	750101-2	Cabinet Assembly, w/Legs-6000. Specify Color.
	750101-3	Cabinet Assembly, w/Legs-6000XL. Specify Color.
2	420142	Pin, Cabinet Receptacle.
3	680303	Cabinet Harness Complete. 5 Shelf.
	680304	Cabinet Harness Complete. 6 Shelf.
4	201373	Receptacle Mounting Plug.
5	276-8R6	Screw, Pan Hd. Self-Tap (8-32 x 3/8).
6	420040-7	Snap Bushing 1-5/8 Diameter.
7	300167	Pin.
8	420045	Rubber Bumper.
9	680270-3	Assembly Complete Main Junction Box. (See Page 38 for Itemized Parts)
10	660240-1	Assembly Complete. Cord Set.
	680321-1	Assembly, Complete Cord Set, Export Only.
	660386	Assembly Coimplete, Grounding, Export Only.
	100-B41-24	Brass Screw, Export Only. (1/4 x 20 x 1 1/2).
	404-B41	Brass Nut, Qty. 4, Export Only. (1/4 x 20).
	380224	Keeper Washer, Qty. 4, Export Only.
	630-416	Lock Washer, 1/4, Export Only.
11	420040-4	Snap Bushing. 1-5/16 Diameter.
12	276-8R6B	Screw, Pan Hd. #23 Phillips (8-32 x 3/8).
13	360083	Transformer.
	360094	Transformer, Export Only.
14	201453	Gum & Mint Tray Catch.
15	201415	Gum & Mint Mounting Bracket Plug.
	201415-1	Gum & Mint Mounting Bracket Plug. Export Only.
16	380230	Plug only.
17	277-10R8	Screw Pan Hd. Phillips Type 23. (10-32 x 1/2).

Item No.	Part No.	Description
18	660317	Gum & Mint Shelf Complete-6000.
	660317-2	Gum & Mint Shelf Complete-6000XL. (See Page 35 for Itemized Parts).
19	600435	Lower Guide Channel.
20	600179-1	Cash Box w/Handle.
21	600436	Cash Box Mounting Bracket.
22		(See Page 29 for Itemized Parts).
23	201563	Control Panel Stop.
24	200816	Roller Channel Stop Bracket.
25	600433	Door Lock Catch. Heavy Duty.
26	300137	Screw, Shelf Roller.
27	440277	Shelf Roller.
28	660318	Assembly Complete. Roller Channel.
	201431	Roller Channel Only.
29	600434	Roller Channel Mounting Bracket. Upper.
30	750097	Lock and Cam for Cash Box. w/2 Keys. Specify Number.
	420020	Lock only w/1 Key. Specify number.
	420069	Cam Cash Box Locking only.
31	201562	Control Panel Top Stop Bracket.
32	750146	Kit Anchoring Bracket. (Consists of 2 Brackets with Hardware).
	202016	Anchoring Bracket only.
33	118-41-12	Carriage Bolt. (1/4-20 x 3/4).
	410-41	Hex Nut. (1/4-20) Not shown.
	600-416	Plain Washer. (1/4) Not shown.

control panel

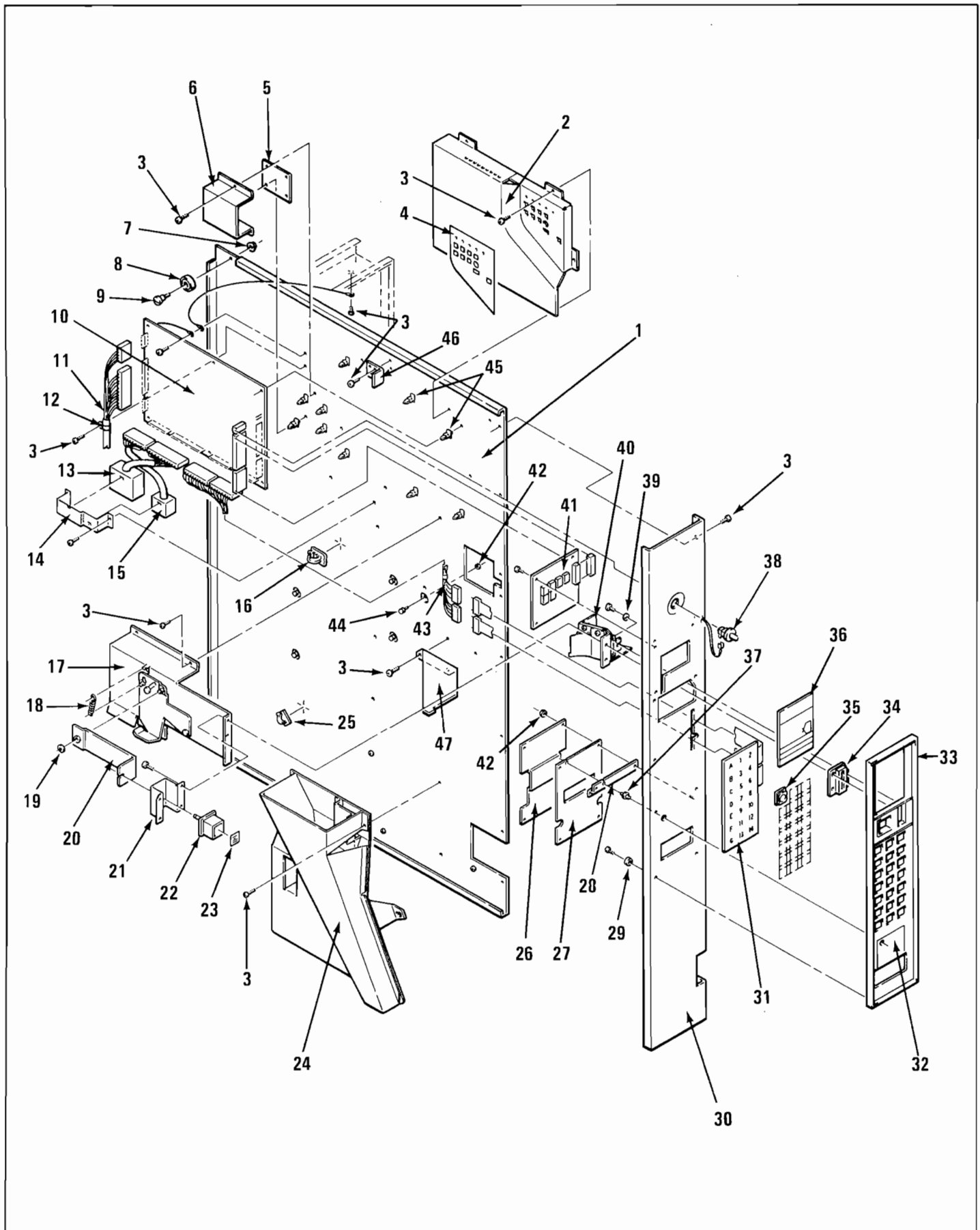

Item No.	Part No.	Description	Item No.	Part No.	Description
1	600439	Control Panel Only.	26	660333	Kit to Mount all Brackets. For Validators, with Decals.
2	201461	Control Board Cover.		201418	Dollar Filler Plate. For Use Without Dollar Acceptors.
3	276-8R6	Screw, Pan Hd. #23 Phillips (8-32 x 3/8).	27	640126	Bracket, Dollar Acceptor Mounting (Ardac Only).
4	460357	Control Board Decal.	28	201433	Bracket, Dollar Acceptor Mounting. (Mars Only).
5	360109	Main Control Power Board.		201517	Bracket, Dollar Acceptor Mounting. Rowe (Upper).
6	201457	Power Board Cover.		201518	Bracket, Dollar Acceptor Mounting. Rowe (Lower).
	460360	Decal "Caution" High Voltage.	29	420144	Ferrule.
7	437-41	Nut, Keps. (1/4 x 28).	30	640124	Control Panel Front Only.
8	440277	Shelf Roller.	31	660266-1	Assembly, Selector Switch Panel.
9	300137	Screw, Shelf Roller.	32	460358	Decal, Dollar. For use with Ardac Dollar Acceptor Only.
10	750115-2	Main Control Board Only.		460359	Decal, Use with No Dollar Acceptor.
	750115-3	Control Board with Digital.		460361	Decal, Dollar. For use with Mars or Rowe Dollar Acceptor.
	360112	Main Control Board, Export Only.	33	320054	Trim, Button and Coin Entrance.
	360111	Control Boards, 4 pcs., Export Only.	34	440279	Coin Entry Trim.
11	680303	Cabinet Harness. Assembly Complete. 5 Shelf.		460362	Coin's Decal. (not shown).
	680304	Cabinet Harness. Assembly Complete. 6 Shelf.		460363	Coin Decal.
12	380078	Tie Wrap Harness.	35	440225	Selector Button.
13	680309	Coinco Changer Hook-Up Harness.	36	440349	Glass Coin Instruction. 5¢, 10¢, 25¢-\$1.00.
14	201130	Changer Plug Mounting Bracket.		440283	Glass Coin Instruction, England.
15	680308	Mars Changer Hook-Up Harness.		440286	Glass Coin Instruction, Australia.
	680319	Mars Changer Hook-Up Harness, Export Only.		440319	Glass Coin Instruction, German.
16	420096	Harness Clamp.		440323	Glass Coin Instruction, Dutch.
17	600422	Assembly Coin Inlet Chute.	37	380240	Dollar Light, "Empty".
18	400034	Spring.	38	380239	Door Operate Mode Switch.
19	751-25	Retaining Ring.	39	600-8	Washer (No. 8).
20	201459	Return Button Link.	40	660289	Assembly, Plastic Coin Chute.
	460374	Decal Return button link		600459	Assembly, Metal Coin Chute.
21	201401	Coin Return Bracket.	41	360106	Digital Display Board.
22	660323	Coin Return Button with Decal.		360097	Connector Ribbon. (not shown).
23	460356	Decal only.	42	438-8	Nut Hex (8-32).
24	600423	Assembly, Coin Cup Chute.	43	680307	Harness, Selector Switch.
25	420097	Harness Clamp	44	300168	Screw, Changer Mounting.
			45	420095	Control Board Stand-offs.
			46	200816	Bracket, Roller Channel Stop.
			47	201466	Control Panel Front Stiffener.

Item No.	Part No.	Description
1	750121-1	Assembly Complete. Snack Shelf. w/o Spirals - 6000.
	750121-2	Assembly Complete. Snack Shelf. w/o Spirals - 6000XL.
	600267-1	Snack Shelf Only - 6000.
	600267-4	Snack Shelf Only - 6000XL.
2	750106	Vend Motor Complete.
3	440287	Spiral Lock.
4	300137	Screw, Shelf Roller.
5	440277	Roller, Shelf.
6	437-41	Nut, Keps. (1/4 - 28).
7	440285	Price and Selection Tab Holder.
8	460346	Item Tabs.
9	460347	Price Tabs. Assorted 15¢ - \$1.50.
	460347-1	Price Tabs. All 30¢ - 35¢.
	460347-2	Price Tabs. All 40¢ - 45¢.
	460347-3	Price Tabs. All 50¢ - 55¢.
	460347-4	Price Tabs. All 60¢ - 65¢.
	460347-5	Price Tabs. All 70¢ - 75¢.
	460347-6	Price Tabs. All 80¢ - 85¢.
	460347-7	Price Tabs. All 90¢ - 95¢.
	460347-8	Price Tabs. All \$1.00 - \$1.05.
	460347-9	Price Tabs. All \$1.10 - \$1.15.
	460347-10	Price Tabs. All \$1.20 - \$1.25.
	460347-11	Price Tabs. All \$1.30 - \$1.35.
	460347-12	Price Tabs. All \$1.40 - \$1.45.
	460347-13	Price Tabs. All \$1.50 - \$1.55.
	460347-14	Price Tabs. All \$1.60 - \$1.65.
	460347-15	Price Tabs. All \$1.70 - \$1.75.
	460347-16	Price Tabs. All \$1.80 - \$1.85.
	460347-17	Price Tabs. All \$1.90 - \$1.95.
	460347-18	Price Tabs. All \$2.00 - \$2.05.
	460347-19	Price Tabs. All \$2.10 - \$2.15.
	460347-20	Price Tabs. All \$2.20 - \$2.25.
	460347-21	Price Tabs. All \$2.30 - \$2.35.
	460347-22	Price Tabs. All \$2.40 - \$2.45.
	460347-23	Price Tabs. All \$2.50 - \$2.55.
	460347-24	Price Tabs. All \$2.60 - \$2.65.
	460347-25	Price Tabs. All \$2.70 - \$2.75.
	460347-26	Price Tabs. All \$2.80 - \$2.85.
	460347-27	Price Tabs. All \$2.90 - \$2.95.
	460347-28	Price Tabs. All \$3.00 - \$3.05.
10	305-8R6	Screw, Pan Hd. Phillips. Plastite. (8-16 x 3/8).
12	640101	Spacer, Snack Shelf. 6000XL.
	640101-1	Spacer, Snack Shelf. 6000.
13	660330-2	Product Rail Assembly. For Use w/Pastry Spiral. 6000XL.
	660330-3	Product Rail Assembly. For Use w/Pastry Spiral 6000.
	440148-2	Plastic Rail Only.

Item No.	Part No.	Description
14	750083	Kit, Can Dispenser Assembly. 6000XL.
	750083-1	Kit, Can Dispenser Assembly. 6000.
15	400124	6 Space. Snack Spiral. 6000.
	400125	8 Space Snack Spiral. 6000.
	400126	10 Space Snack Spiral. 6000.
	400165	4 Space Snack Spiral. 6000.
	400127	10 Space Snack Spiral. 6000XL.
	400127-1	10 Space Snack Spiral, Chrome. 6000XL.
	400128	12 Space Snack Spiral. 6000XL.
	400128-1	12 Space Snack Spiral, Chrome. 6000XL.
	400129	15 Space Snack Spiral. 6000XL.
	400129-1	15 Space Snack Spiral, Chrome. 6000XL.
	400136	30 Space Snack Spiral. 6000XL.
	400136-1	30 Space Snack Spiral, Chrome. 6000XL.
	400137	40 Space Snack Spiral. 6000XL.
	400137-1	40 Space Snack Spiral, Chrome. 6000XL.
	400153	7 Space Snack Spiral. 6000XL.
	400153-1	7 Space Snack Spiral, Chrome. 6000XL.
	400162	6 Space Snack Spiral. 6000XL.
	400162-1	6 Space Snack Spiral, Chrome. 6000XL.
	400163	18 Space Snack Spiral. 6000XL.
	400163-1	18 Space Snack Spiral, Chrome. 6000XL.
16	276-8R6	Screw, Pan Hd. Self-Tap (8-32 x 3/8).
17	420142	Pin, Shelf Plug.
18	680302	Harness, Complete. Pastry Shelf.
19	600246-1	Bracket Only.
20	305-7R8	Screw, Pan hd. Phillips, Plastite. (7 x 1/2).
21	440201	Drive Cam. Rear.
22	751-31	Retaining Ring. #31.
23	440200	Drive Cam. Front.
24	640109	Cam, Mounting Brkt. & Spring Assembly.
25	600308	Can Dispenser. Trough Only. 6000XL.
	600308-1	Can Dispenser. Trough Only. 6000.
26	300184	Shoulder Bushing.
	277-10R8	Screw Type 23 (#10-32 x 1/2).
27	400094	Actuator Wire. 6000XL.
	400084-1	Actuator Wire. 6000.
28	440196	Price and Selection Trim.
29	440199	Stop Lever.
30	440198	Leg, Top Can Guide & Sign Trim.
31	440197	Top, Can Guide & Sign Trim.
32	440125	Spiral Retainer Only.
35	201534	Front Support Only.
36	200913-1	Rear Support Bracket Only.
	200913	Rear Support Bracket Only. For use w/Special Candy Spiral.

candy shelf

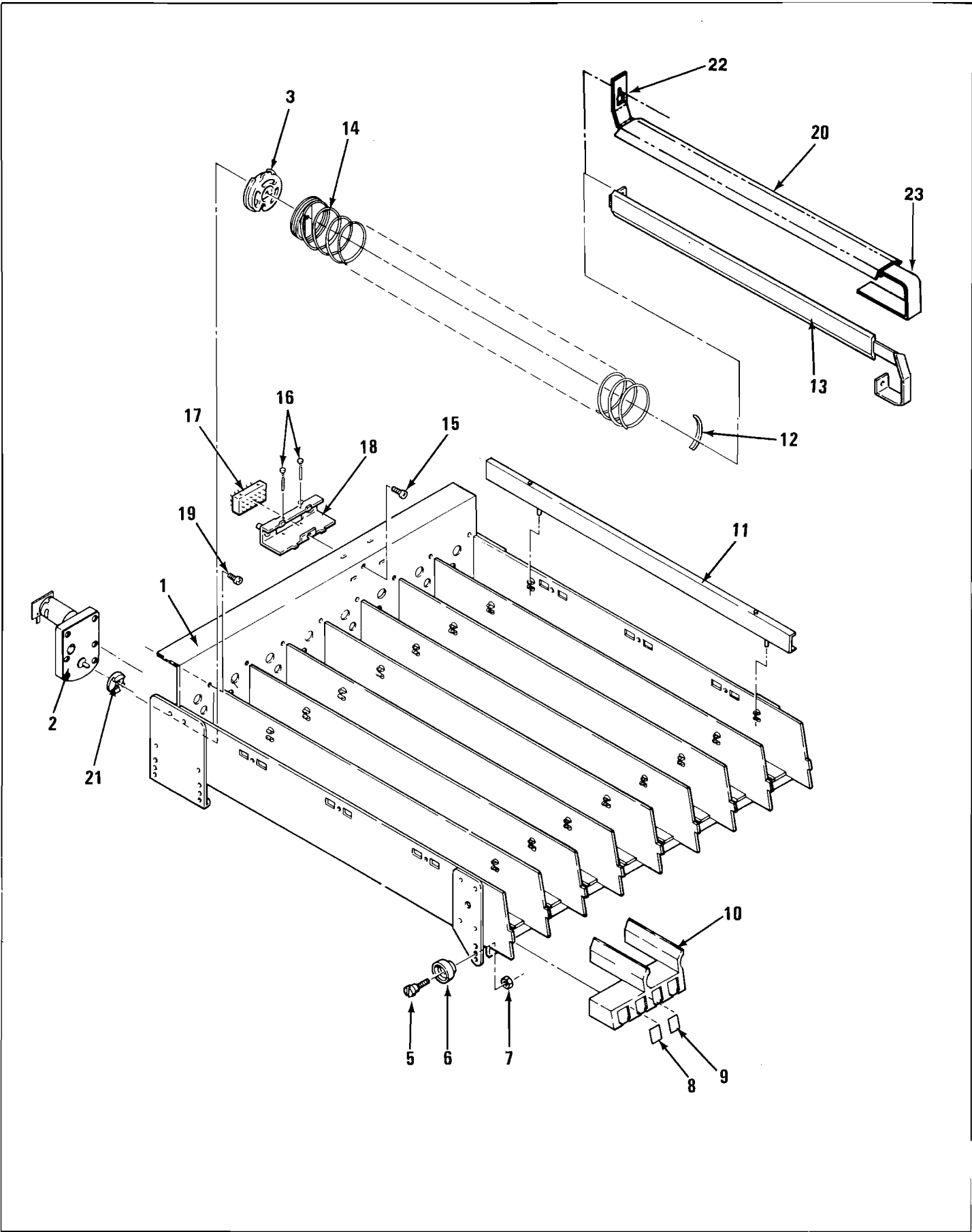

Item No.	Part No.	Description
1	750122-1	Assembly Complete. Candy Shelf. w/o Spirals - 6000.
	750122-2	Assembly Complete. Candy Shelf. w/o Spirals - 6000XL.
	600268-1	Candy Shelf Only - 6000.
	600268-2	Snack Shelf Only - 6000XL.
2	750106	Vend Motor Complete.
	360135	Vend Motor Half-Cycle Brown/Yellow.
3	440287	Spiral Lock.
4	300137	Screw, Shelf Roller.
5	440277	Roller, Shelf.
6	437-41	Nut, Keps. (1/4 - 28).
8	460346	Item Tabs.
9	460347	Price Tabs. Assorted 15¢ - \$1.50.
	460347-1	Price Tabs. All 30¢ - 35¢.
	460347-2	Price Tabs. All 40¢ - 45¢.
	460347-3	Price Tabs. All 50¢ - 55¢.
	460347-4	Price Tabs. All 60¢ - 65¢.
	460347-5	Price Tabs. All 70¢ - 75¢.
	460347-6	Price Tabs. All 80¢ - 85¢.
	460347-7	Price Tabs. All 90¢ - 95¢.
	460347-8	Price Tabs. All \$1.00 - \$1.05.
	460347-9	Price Tabs. All \$1.10 - \$1.15.
	460347-10	Price Tabs. All \$1.20 - \$1.25.
	460347-11	Price Tabs. All \$1.30 - \$1.35.
	460347-12	Price Tabs. All \$1.40 - \$1.45.
	460347-13	Price Tabs. All \$1.50 - \$1.55.
	460347-14	Price Tabs. All \$1.60 - \$1.65.
	460347-15	Price Tabs. All \$1.70 - \$1.75.
	460347-16	Price Tabs. All \$1.80 - \$1.85.
	460347-17	Price Tabs. All \$1.90 - \$1.95.
	460347-18	Price Tabs. All \$2.00 - \$2.05.
	460347-19	Price Tabs. All \$2.10 - \$2.15.
	460347-20	Price Tabs. All \$2.20 - \$2.25.
	460347-21	Price Tabs. All \$2.30 - \$2.35.
	460347-22	Price Tabs. All \$2.40 - \$2.45.
	460347-23	Price Tabs. All \$2.50 - \$2.55.
	460347-24	Price Tabs. All \$2.60 - \$2.65.
	460347-25	Price Tabs. All \$2.70 - \$2.75.
	460347-26	Price Tabs. All \$2.80 - \$2.85.
	460347-27	Price Tabs. All \$2.90 - \$2.95.
	460347-28	Price Tabs. All \$3.00 - \$3.05.
10	440262	Price and Selection Tab Holder.
11	660178	Assembly Candy Spacer. 6000XL.
	660178-2	Assembly Candy Spacer. 6000.
	660178-3	Assembly Candy Spacer. For Use w/Half Cycle Motor. 6000.
	660178-4	Assembly Candy Spacer. Export. Use w/Half Cycle Motor. 6000XL.

Item No.	Part No.	Description
12	440141-1	Candy Product Pusher.
13	600589	Product Guide Assembly. For Use w/Half Cycle Motor. 6000XL.
	600589-1	Product Guide Assembly. For Use w/Half Cycle Motor. 6000.
	600296	Small Product Guide. For Use w/Thin Mints. 6000XL.
	660296-1	Small Product Guide. For Use w/Tin Mints. 6000.
14	400116	8 Space. Candy Spiral. 6000.
	400117	10 Space Candy Spiral. 6000.
	400118	12 Space Candy Spiral. 6000.
	400119	16 Space Candy Spiral. 6000.
	400134	20 Space Candy Spiral. 6000.
	400120	12 Space Candy Spiral. 6000XL.
	400120-1	12 Space Candy Spiral, Chrome. 6000XL.
	400121	15 Space Candy Spiral. 6000XL.
	400121-1	15 Space Candy Spiral, Chrome. 6000XL.
	400122	18 Space Candy Spiral. 6000XL.
	400122-1	18 Space Candy Spiral, Chrome. 6000XL.
	400123	24 Space Candy Spiral. 6000XL.
	400123-1	24 Space Candy Spiral, Chrome. 6000XL.
	400135	30 Space Candy Spiral. 6000XL.
	400135-1	30 Space Candy Spiral, Chrome. 6000XL.
	400138	40 Space Candy Spiral. 6000XL.
	400138-1	40 Space Candy Spiral, Chrome. 6000XL.
	400164	7 Space Candy Spiral. 6000XL.
	400164-1	7 Space Candy Spiral, Chrome. 6000XL.
	400166	9 Space Candy Spiral. 6000XL.
	400166-1	9 Space Candy Spiral, Chrome. 6000XL.
	400167	6 Space Candy Spiral. 6000XL.
	400167-1	6 Space Candy Spiral, Chrome. 6000XL.
	400168	10 Space Candy Spiral. 6000XL.
	400168-1	10 Space Candy Spiral, Chrome. 6000XL.
15	276-8R6	Screw, Pan Hd. Self-Tap (8-32 x 3/8).
16	420142	Shelf Plug. Pin.
17	680300	Harness, Complete. Candy Shelf.
18	600246-1	Bracket Only.
19	305-7R8	Screw, Pan hd. Phillips, Plastite. (#7 x 1/2).
20	660191	Product Rail Assembly. For Use With A Candy Spiral. 6000.
	440148-1	Plastic Rail Only. 6000XL.
	660191-2	Product Rail Assembly. For Use With A Candy Spiral. 6000.
	440148-2	Plastic Rail Only. 6000.
21	440125	Spiral Retainer Only.
22	200913	Rear Support Bracket Only.
23	201258	Front Support Bracket Only.

Convertible Shelf

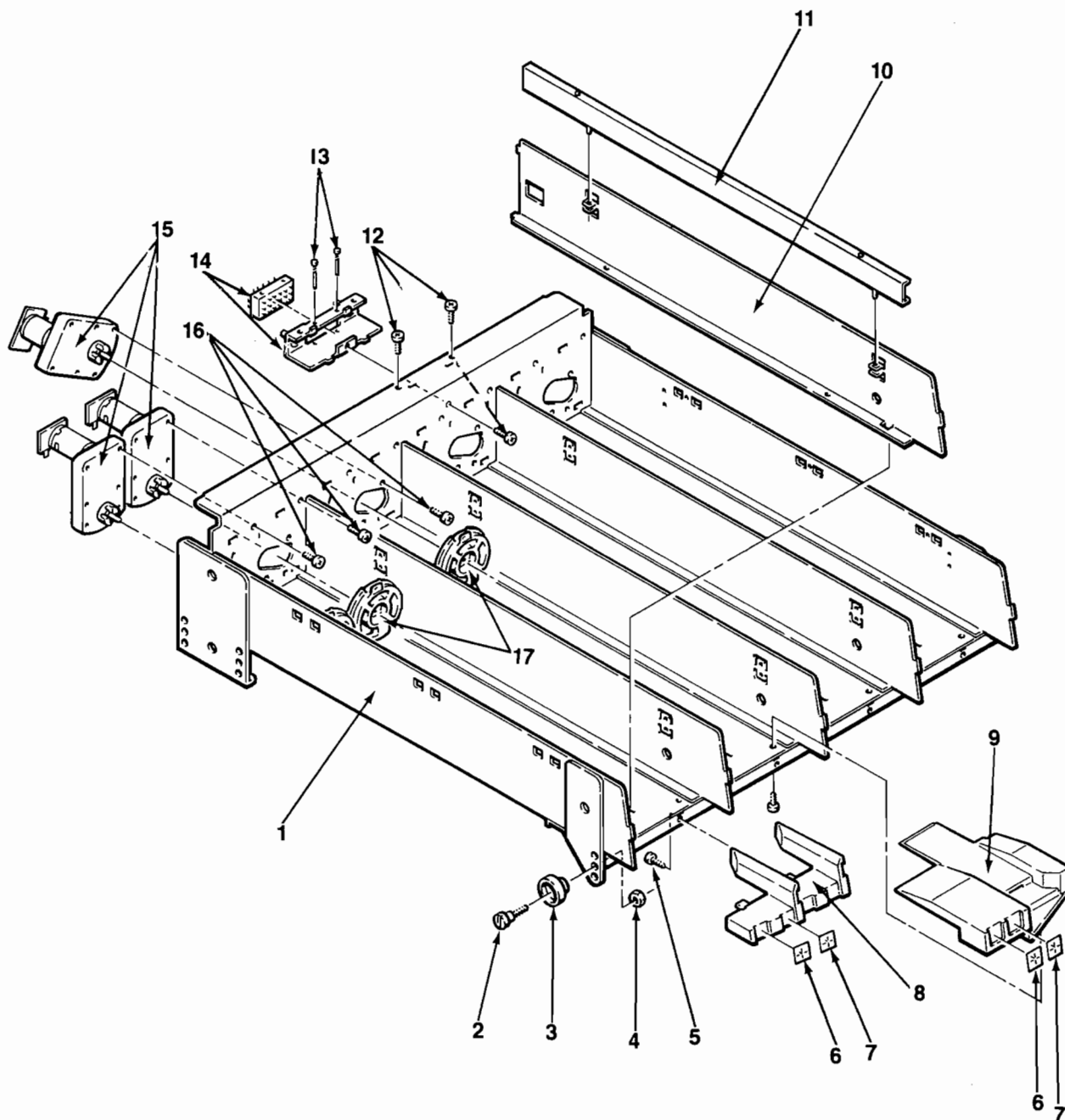

Item No.	Part No.	Description
1	750148	Assembly Complete. Convertible Shelf. (4 Snack Selections) wo/Spirals. 6000.
	750148-1	Assembly Complete. Convertible Shelf. (3 Snack Selections and 2 Candy) wo/Spirals. 6000.
	750148-2	Assembly Complete. Convertible Shelf. (2 Snack Selections and 4 Candy) wo/Spirals. 6000.
	750148-3	Assembly Complete. Convertible Shelf. (1 Snack Selection and 6 Candy) wo/Spirals. 6000.
	750148-4	Assembly Complete. Convertible Shelf. (8 Candy Selections) wo/Spirals. 6000.
	750149	Assembly Complete. Convertible Shelf. (4 Snack Selections) wo/Spirals. 6000XL.
	750149-1	Assembly Complete. Convertible Shelf. (3 Snack Selections and 2 Candy) wo/Spirals. 6000XL.
	750149-2	Assembly Complete. Convertible Shelf. (2 Snack Selections and 4 Candy) wo/Spirals. 6000XL.
	750149-3	Assembly Complete. Convertible Shelf. (1 Snack Selection and 6 Candy) wo/Spirals. 6000XL.
	750149-4	Assembly Complete. Convertible Shelf. (8 Candy Selections) wo/Spirals. 6000XL.
	600267-3	Convertible Snack Shelf Only. 6000.
	600267-4	Convertible Snack Shelf Only. 6000XL.
2	300137	Screw Shelf Roller.
3	440277	Roller, Shelf.
4	437-41	Nut Keps (1/4-28).
5	305-8R6	Screw Pan Hd. Phillips Plastite (8-16 x 3/8).
6	460346	Item Tabs.
7	460347	Price Tabs. Assorted 15¢ - \$1.50.
	460347-1	Price Tabs. All 30¢ - 35¢.
	460347-2	Price Tabs. All 40¢ - 45¢.
	460347-3	Price Tabs. All 50¢ - 55¢.
	460347-4	Price Tabs. All 60¢ - 65¢.
	460347-5	Price Tabs. All 70¢ - 75¢.
	460347-6	Price Tabs. All 80¢ - 85¢.

Item No.	Part No.	Description
	460347-7	Price Tabs. All 90¢ - 95¢.
	460347-8	Price Tabs. All \$1.00 - \$1.05.
	460347-9	Price Tabs. All \$1.10 - \$1.15.
	460347-10	Price Tabs. All \$1.20 - \$1.25.
	460347-11	Price Tabs. All \$1.30 - \$1.35.
	460347-12	Price Tabs. All \$1.40 - \$1.45.
	460347-13	Price Tabs. All \$1.50 - \$1.55.
	460347-14	Price Tabs. All \$1.60 - \$1.65.
	460347-15	Price Tabs. All \$1.70 - \$1.75.
	460347-16	Price Tabs. All \$1.80 - \$1.85.
	460347-17	Price Tabs. All \$1.90 - \$1.95.
	460347-18	Price Tabs. All \$2.00 - \$2.05.
	460347-19	Price Tabs. All \$2.10 - \$2.15.
	460347-20	Price Tabs. All \$2.20 - \$2.25.
	460347-21	Price Tabs. All \$2.30 - \$2.35.
	460347-22	Price Tabs. All \$2.40 - \$2.45.
	460347-23	Price Tabs. All \$2.50 - \$2.55.
	460347-24	Price Tabs. All \$2.60 - \$2.65.
	460347-25	Price Tabs. All \$2.70 - \$2.75.
	460347-26	Price Tabs. All \$2.80 - \$2.85.
	460347-27	Price Tabs. All \$2.90 - \$2.95.
	460347-28	Price Tabs. All \$3.00 - \$3.05.
8	440262	Price and Selection Tab Holder. Offset. Candy. (Please see page 33 Item #14 for Candy Spirals.
9	440285	Price and Selection Tab Holder. Snack. (Please see page 31 Item #15 for Snack Spirals.
10	200745-2 200763-6	Shelf Divider. Candy. 6000.
	200753-2	Shelf Divider. Candy. 6000XL.
11	660178-2	Assembly Candy Spacer. 6000.
	660178	Assembly Candy Spacer. 6000XL.
12	276-8R6	Screw, Pan Hd. Self-Tap. (8-32 x 3/8).
13	420142	Pin, Shelf Plug.
14	680339	Harness, Candy Shelf w/Plug Bracket.
15	750106	Vend Motor Complete.
16	305-7R8	Screw, Pan Hd. Phillips, Plastite (7 x 1/2).
17	440287	Spiral Lock.

gum & mint shelf

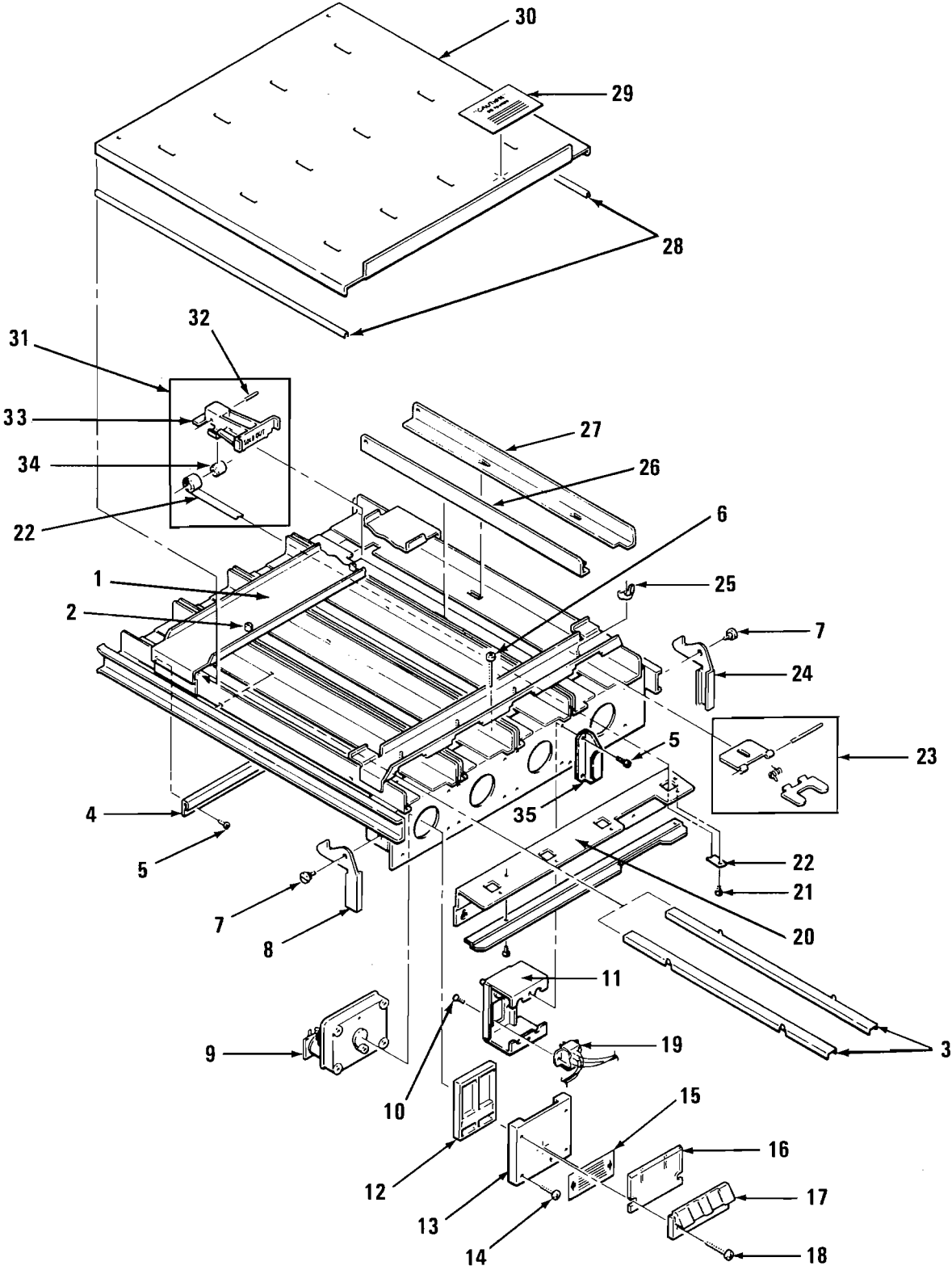

Item No.	Part No.	Description
1	660317	Assembly Complete. Gum & Mint Shelf. 6000.
	660317-2	Assembly Complete. Gum & Mint Shelf. 6000XL.
	660317-3	Assembly Complete, Gum & Mint Shelf. 6000. Export Only.
	660317-4	Assembly Complete. Gum & Mint Shelf. 6000XL. Export Only.
	600421	Gum & Mint Shelf Only. 6000.
	660421-2	Gum & Mint Shelf Only. 6000XL.
	600463	Gum & Mint Shelf Only. 6000. Export Only.
	600463-1	Gum & Mint Shelf Only. 6000 XL. Export Only.
2	420049-9	Snap Bushing and Hole Plug.
3	201412	Thin Mint Adapter (2 per selection) 6000XL.
	201412-1	Thin Mint Adapter (2 per selection) 6000.
4	201458-1	Gum and Mint Rear Pusher Stop.
	201458-3	Gum & Mint Rear Pusher Stop. Export Only.
5	276-8R6	Screw, Pan Hd. Self-Tap Phillips (8-32 x 3/8).
6	217-8R22	Screw, Pan Hd. Phillips Type AB (1-3/8).
7	300184	Shoulder Bushing.
	277-10R8	Screw, Type 23 (#10-32 x 1/2).
8	201454-1	Gum and Mint Shelf Latch. Left Side.
9	360105	Gum and Mint Motor.
10	420089	Screw, 100° Flat Hd. (6-32 x 1/2).
11	600427	Gum and Mint Plug Mounting Bracket.
12	440267	Ejector, Gum and Mint.
13	440266	Gum and Mint Shelf Front Base.
14	395-7R16	Screw, Pan Hd. Plastite (#7 x 1).
15	460352	Decal, Gum and Mint Shelf Latch.
16	440270	Display Stop. Gum & Mint Column Front.
17	440273	Gum and Mint Shelf Front.
18	305-7R22	Screw, Pan Hd. Plastite (#7 x 1-3/8).

Item No.	Part No.	Description
19	680306	Harness, Gum, and Mint Shelf.
	380229	Gum and Mint Shelf Plug Only.
	680328	Harness Only, Gum & Mint Shelf. Export Only.
	660341-1	Harness And Bracket Only, Gum & Mint Shelf. Export Only.
20	201414-1	Strap, Gum and Mint Pusher Stop.
	201553	Strap, Gum & Mint Pusher Stop. Export Only.
21	262-6R5	Screw, Flat Hd. Phillips Type 23 (6-32 x 5/16)
22	400106	Spring, Gum and Mint Pusher Return.
23	660314	Assembly, Complete Gum and Mint Display. Hinge.
24	201454	Gum and Mint Shelf Latch. Right Side.
25	420023	Wing Nut (8-32).
26	201411-1	Column Spacer. Left. 6000XL.
	201411-3	Column Spacer. Left. 6000.
27	201411	Column Spacer. Right. 6000XL.
	201411-2	Column Spacer. Right. 6000.
28	420090-3	Shelf Grommet (NGS #1 22) 6000XL.
	420090-4	Shelf Grommet (NGS #1 14) 6000.
29	460351	Decal, Caution. Gum and Mint Shelf.
30	201409-1	Cover, Gum & Mint Shelf. 6000.
	201409-2	Cover, Gum & Mint Shelf. 6000XL.
	201530-1	Gum & Mint Shelf Cover. 6000. Export Only.
	201530-2	Gum & Mint Shelf Cover. 6000 XL. Export Only.
31	660313	Assembly Complete. Gum and Mint Pusher and Spring.
32	801C-125-12	Roll Pin (1/8 x 3/4).
33	440265	Pusher Only.
34	440274	Roller, Gum and Mint Pusher.
35	201691	G & M Shelf Closer.

delivery bin

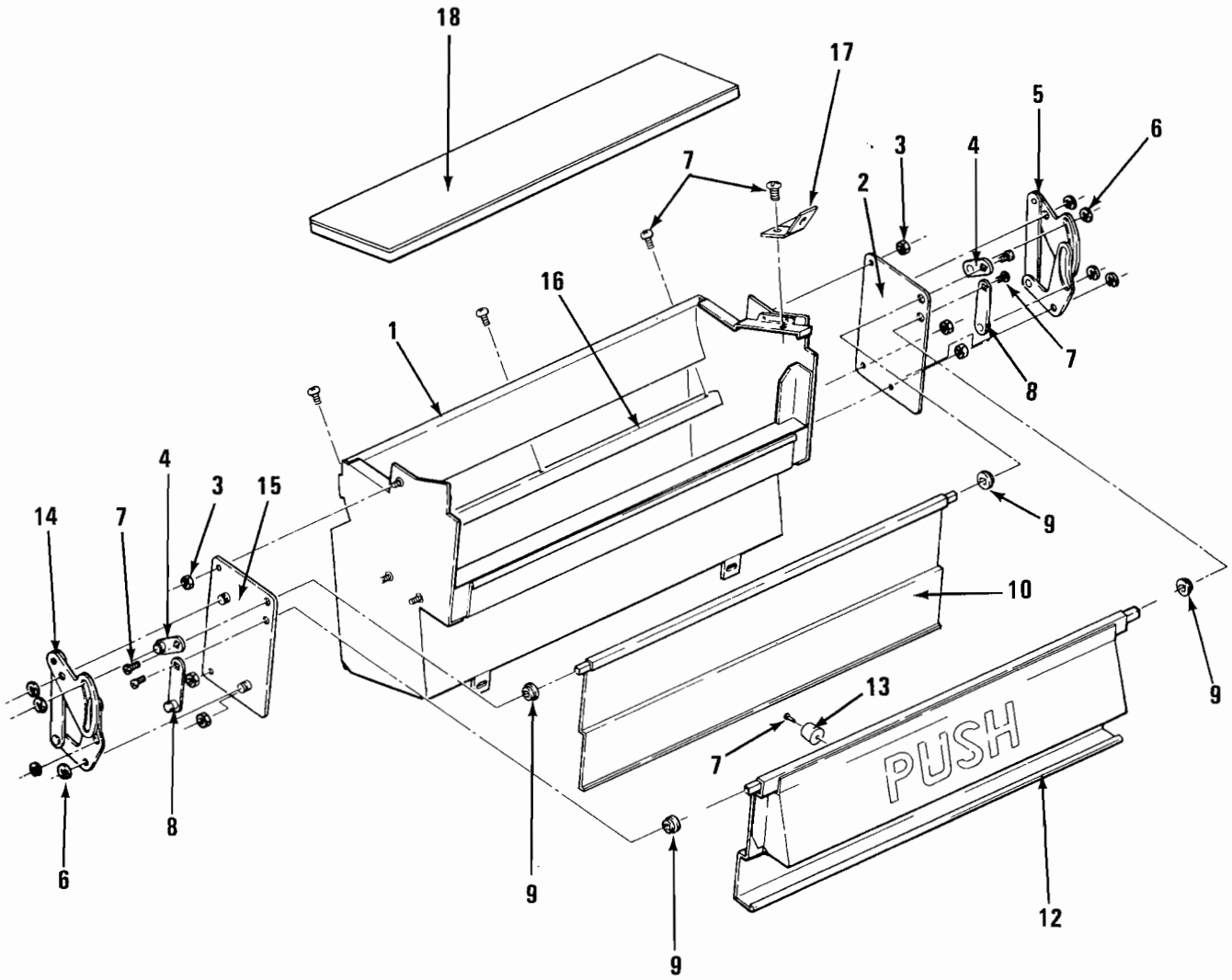

Item No.	Part No.	Description
1	660310-1 600407-1	Delivery Bin Assembly. Complete. Delivery Bin.
2	750161-1 640099	Assembly Complete. Delivery Bin End (Lock Side). Arm Mounting Bracket (Lock Side).
3	438-8	Nut, Keps. No. 8-32.
4	640098	Inner Door Bin Arm.
5	640100	Bin Door Drive Assembly (Lock Side).
6	751-37	Retaining Ring No. 37.
7	276-8R6	Screw, Pan Hd. Phillips. Self Tap. No. 8-32 x 3/8".
8	640097	Door Drive Arm.

Item No.	Part No.	Description
9	440129	Door Bearing.
10	200763-1	Inner Door.
12	600258-1	Door, Delivery Bin.
13	420029	Rubber Bumper.
14	640100-1	Bin Door Drive Assembly (Pivot Side).
15	750161 640099-1	Assembly Complete. Delivery Bin End (Pivot Side). Arm Mounting Bracket. (Pivot Side).
16	200902-1	Baffle, Rear Delivery Bin.
17	200906	Delivery Bin Anchor Strap.
18	660238-1	Delivery Bin Pad Assembly for Can Dispenser.

main junction box

Item No.	Part No.	Description
1	2006R6	Screw, Rd. Hd. Phillips (6-18 x 3/8).
2	201189	Cover, Ballast and Switch Bracket.
3	680270-3	Assembly Complete. Junction Box.
	201153	Box Only.
	680312	Harness, Under Shelf (Not Shown)
	380269	Capacitor .1uf (Not Shown).
	680270-4	Assembly Complete. Main Junction Box. Export.
	680270-5	Assembly Complete. Main Junction Box. Germany & Holland.
4	680278	Assembly Complete. Ballast. 19-25 Watt.

Item No.	Part No.	Description
5	276-8R4B	Screw, Pan Hd. Phillips Type 23. (8-32 x 1/4).
6	276-6R4	Screw, Pan Hd. Phillips Type 23. (6-32 x 1/4).
7	380243	Toggle Switch.
8	380241	Circuit Breaker, 3 Amp.
9	380189	Molex Receptacle. 2 Pin.
10	380034	Molex Plug. 3 Pin.
11	380035	Molex Receptacle. 3 Pin.
12	380107	Molex Receptacle. 6 Pin.
13	380106	Molex Plug. 6 Pin.

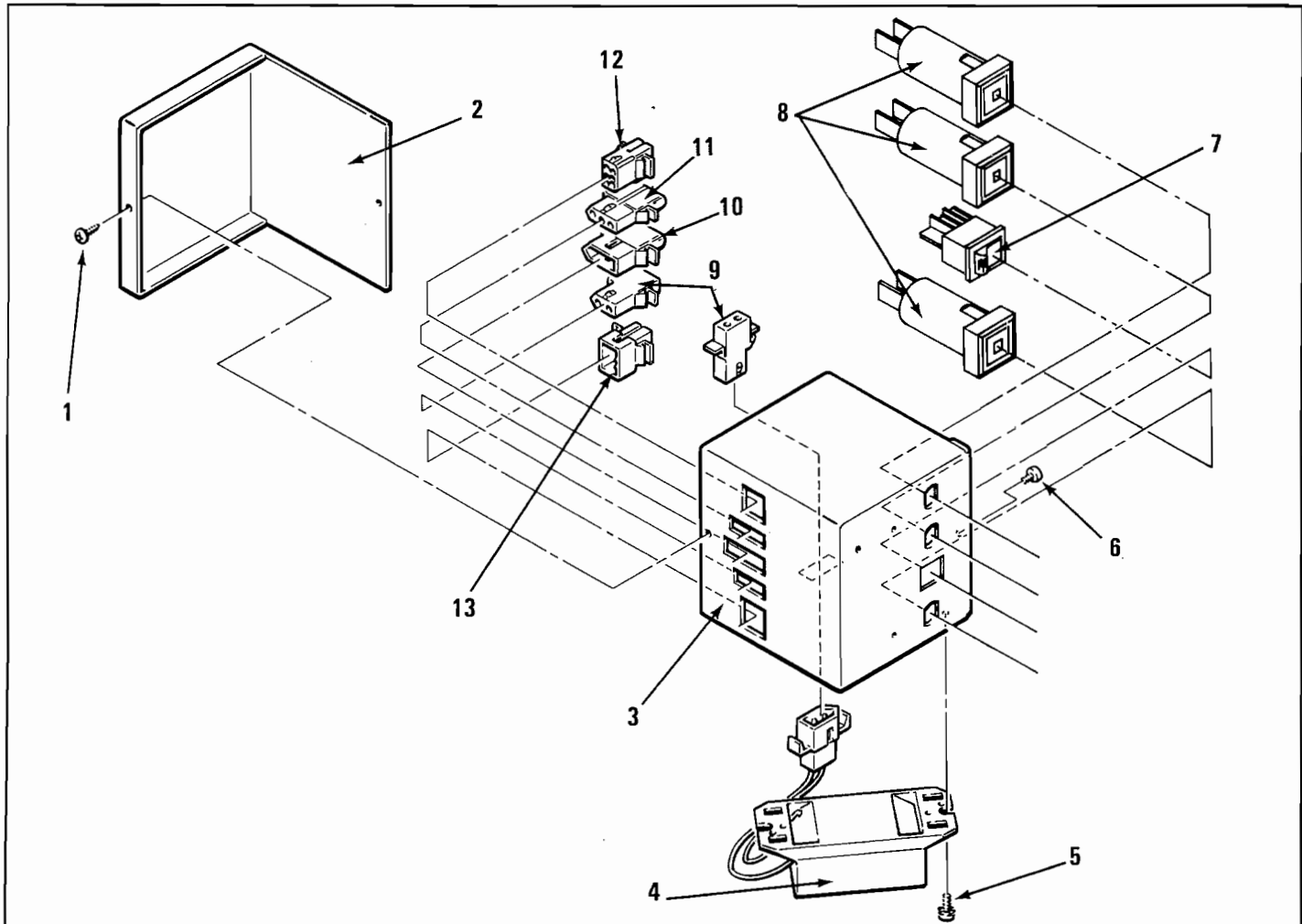

electrical harnesses

Part No.	Description
360086	Cord Set
660240-1	Assembly Complete. Cord Set.
680139-4	Light Cord Harness.
680306	Harness, Gum and Mint Shelf.
680300	Harness, Candy Shelf
680302	Harness, Pastry Shelf.
680315	Harness, Mars Validator Hook-Up.
680312	Harness, Under Shelf.
360097	Harness, Ribbon Connector to Digital Display.

Part No.	Description
680303	Cabinet Back Harness (6500) 5 Shelves.
680304	Cabinet Back Harness (6600) 6 Shelves.
680309	Harness, Coinco Changer Hook-Up.
680308	Harness, Mars Changer Hook-Up.
680307	Harness, Selector Switch Panel.
680275	Fan Cord. Harness.
680138	Assembly Lamp Harness.
680310	Operate Switch Harness.

Item No.	Part No.	Description
1	340044-6	Trim, Top. For use with Vinyl Insert.
2	440258-5	Insert, Top Trim. "Snacks".
3	340057-	Trim, Outside Vertical. Right or Left.
4	340058-2	Trim, Inside Vertical.
5		Panel, Left Side Vertical.
	200792-34	Presidential Walnut.
	200792-35	Regency Walnut.
	200792-36	Kashmire Walnut.
	200792-37	Honeytone Teak.
	200792-38	Spanish Oak.
	200792-39	Imperial Rosewood.
	200792-41	Painted. Specify Color.
6	340058-1	Trim, Inside Horizontal.
7		Panel, Vinyl. Delivery Tray.
	201356-8	Presidential Walnut.
	201356-30	Regency Walnut.
	201356-33	Kashmire Walnut.
	201356-11	Honeytone Teak.
	201356-12	Spanish Oak.
	201356-13	Imperial Rosewood.
	201356-14	Painted. Specify Color.
8	340055-6	Trim, Horizontal.
9		Panel, Lower Horizontal.
	200296-2	Presidential Walnut.
	200296-3	Regency Walnut.
	200296-16	Kashmire Walnut.
	200296-17	Honeytone Teak.
	200296-18	Spanish Oak.
	200296-25	Imperial Rosewood.
	200296-26	Painted. Specify Color.
10		Panel, Right Side Vertical.
	201357-8	Presidential Walnut
	201357-48	Regency Walnut.
	201357-10	Kashmire Walnut.
	201357-11	Honeytone Teak.
	201357-12	Spanish Oak.
	201357-13	Imperial Rosewood.
	201357-15	Painted. Specify Color.
11	600429	Door Only. Specify Color.

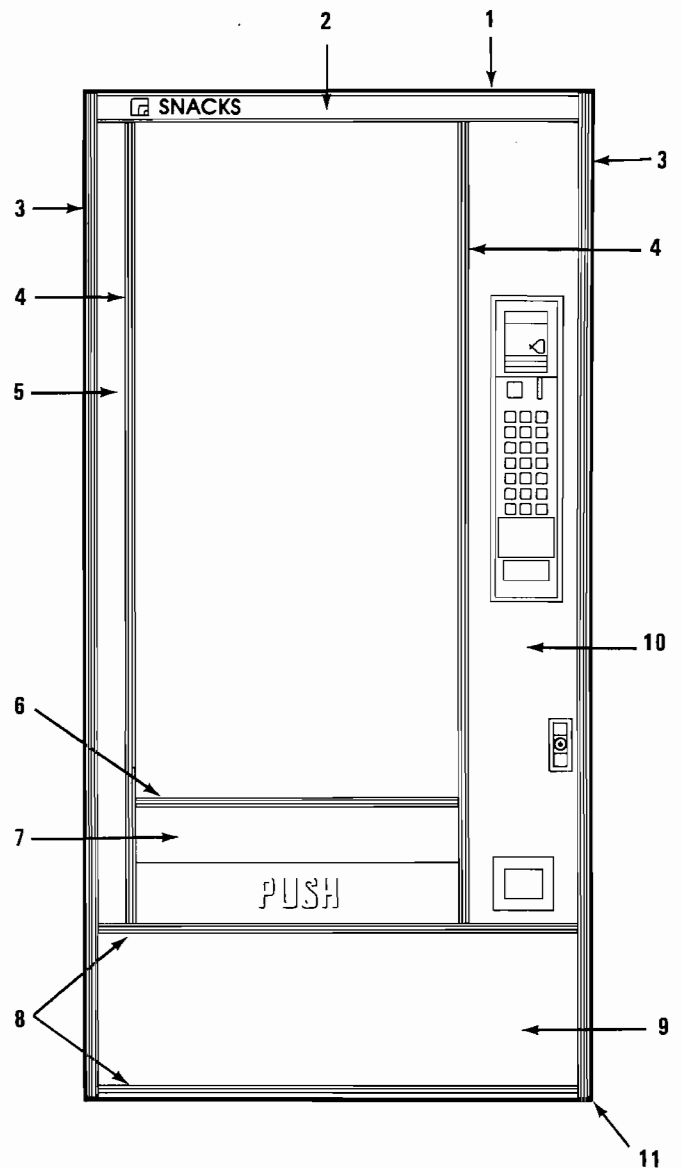

cover-up plate 3

Item No.	Part No.	Description
1	660231-18	Trim, Horizontal w/Black Stripe.
2		Panel, Coverplate 3".
	201417-1	Presidential Walnut, Vinyl.
	201417-7	Regency Walnut, Vinyl.
	201417-8	Honeytone Teak, Vinyl.
	201417-9	Painted, Specify Color.
3	340057	Trim, Outside Vertical. (Right or Left).
4	340058-4	Trim, Inside Vertical. (Right or Left).
5		Panel, Left Side Vertical.
	200792-56	Presidential Walnut, Vinyl.
	200792-61	Regency Walnut, Vinyl.
	200792-62	Honeytone Teak, Vinyl.
	200792-63	Painted, Specify Color.
	200792-57	Port Au Prince, Vinyl.
6	340058-1	Trim, Inside Horizontal.
7		Panel, Delivery Tray.
	201356-8	Presidential Walnut, Vinyl.
	201356-30	Regency Walnut, Vinyl.
	201356-11	Honeytone Teak, Vinyl.
	201356-14	Painted, Specify Color.
8		Panel, Lower Horizontal.
	200296-2	Presidential Walnut, Vinyl.
	200296-3	Regency Walnut, Vinyl.
	200296-17	Honeytone Teak, Vinyl.
	200296-26	Painted, Specify Color.
9		Panel, Right Side Vertical.
	201357-30	Presidential Walnut, Vinyl.
	201357-35	Regency Walnut, Vinyl.
	201357-36	Honeytone Teak, Vinyl.
	201357-37	Painted, Specify Color.
	201357-31	Port Au Prince, Vinyl.
10	600429	Door Only, Specify Color.

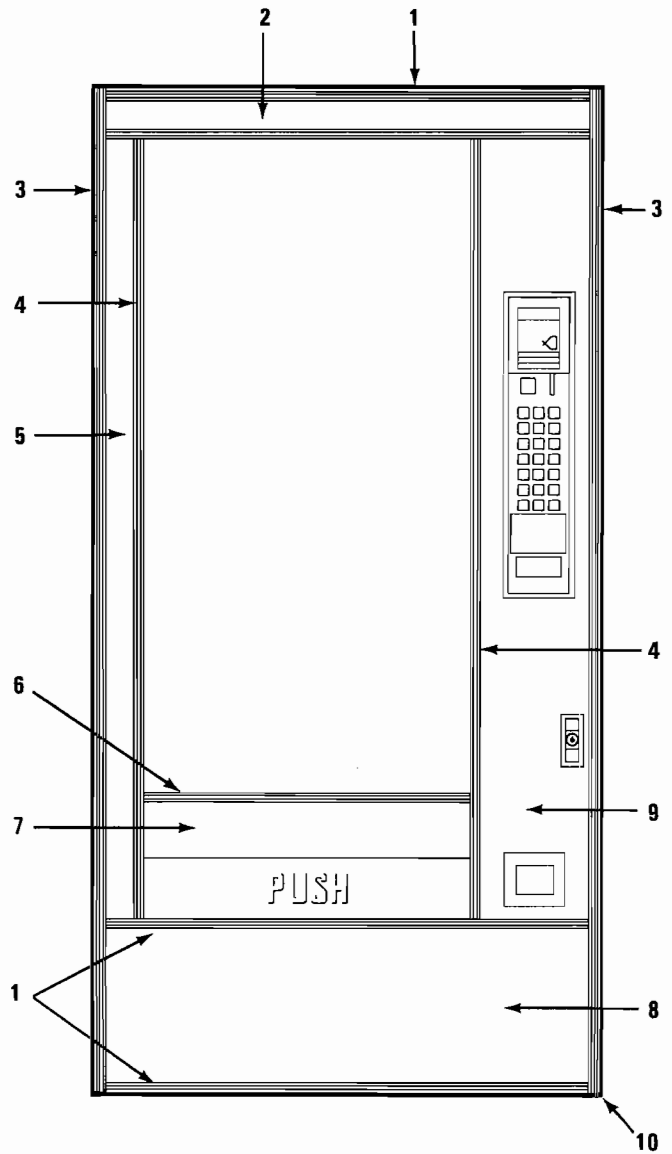

Item No.	Part No.	Description
1	201094-1	Panel, Coverplate 5"
	201094-2	Presidential Walnut Vinyl.
	201094-3	Honeytone Teak Vinyl.
	201094	Regency Walnut Vinyl. Painted, Specify Color.
2	660231-18	Trim Horizontal. w/Black Stripe.
3	340057	Trim, Outside Vertical. Right or Left.
4	340058-3	Trim, Inside Vertical. Right or Left.
5	200792-49	Panel, Left Side Vertical.
	200792-51	Presidential Walnut Vinyl.
	200792-50	Honeytone Teak Vinyl.
	200792-53	Regency Walnut Vinyl. Painted, Specify Color.
6	340058-1	Trim, Inside Horizontal.
7	201356-8	Panel, Delivery Tray.
	201356-11	Presidential Walnut Vinyl.
	201356-30	Honeytone Teak Vinyl.
	201356-14	Regency Walnut vinyl. Painted, Specify Color.
8	200296-2	Panel, Lower Horizontal.
	200296-17	Presidential Walnut Vinyl.
	200296-3	Honeytone Teak Vinyl.
	200296-26	Regency Walnut Vinyl. Painted, Specify Color.
9	201357-23	Panel, Right Side Vertical.
	201357-25	Presidential Walnut Vinyl.
	201357-24	Honeytone Teak Vinyl.
	201357-27	Regency Walnut Vinyl. Painted, Specify Color.
10	600429	Door Only, Specify Color.

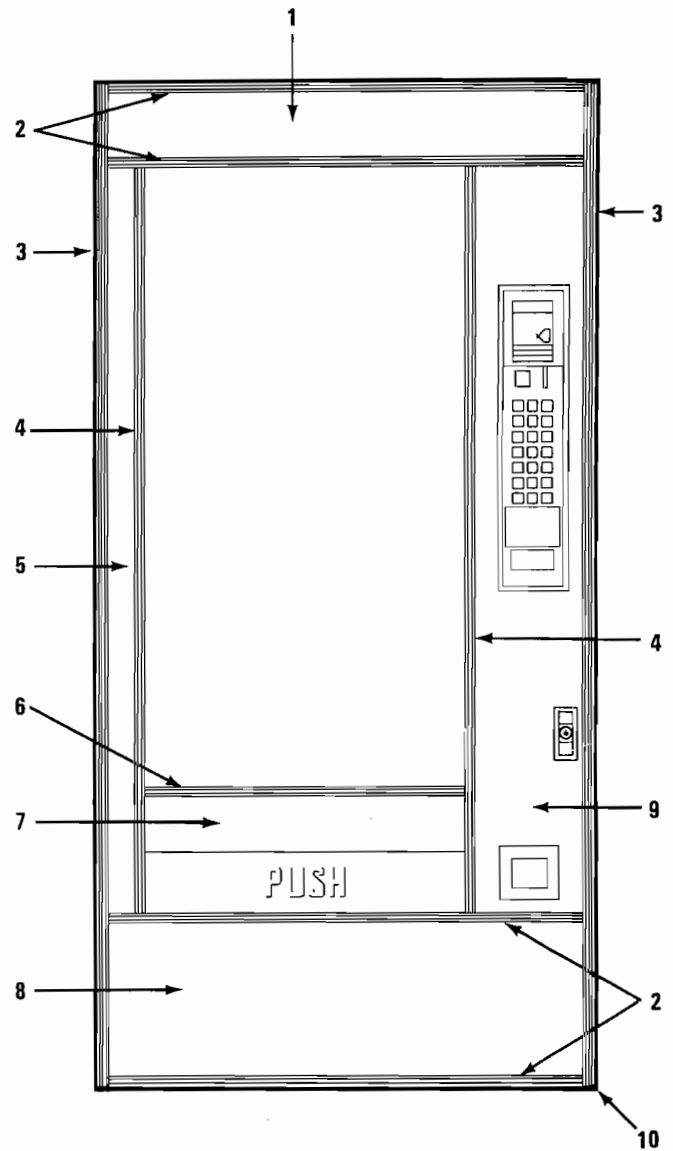

imperial I style

Item No.	Part No.	Description
1	660231-18	Trim, Horizontal w/Black Stripe.
2	440159	Frame, Plastic.
	211-8R4	Screw, Truss Hd. Phillips Type B (#8 x 1/4).
3	440154	Panel, Insert.
4		Cover Up Plate.
	201094-7	Presidential Walnut Vinyl.
5	340057	Trim, Outside Vertical. Right or Left.
6	340058-3	Trim, Inside Vertical. Right or Left.
7		Panel, Left Side Vertical.
	200792-49	Presidential Walnut Vinyl.
	200792-52	Burlap.
8	340058-1	Trim, Inside Horizontal.
9		Panel, Delivery Tray.
	201356-8	Presidential Walnut Vinyl.
10		Panel, Lower Horizontal.
	200296-2	Presidential Walnut Vinyl.
11		Panel, Right Side Vertical.
	201357-23	Presidential Walnut Vinyl.
	201357-26	Burlap.
12	600429	Door Only, Specify Color.

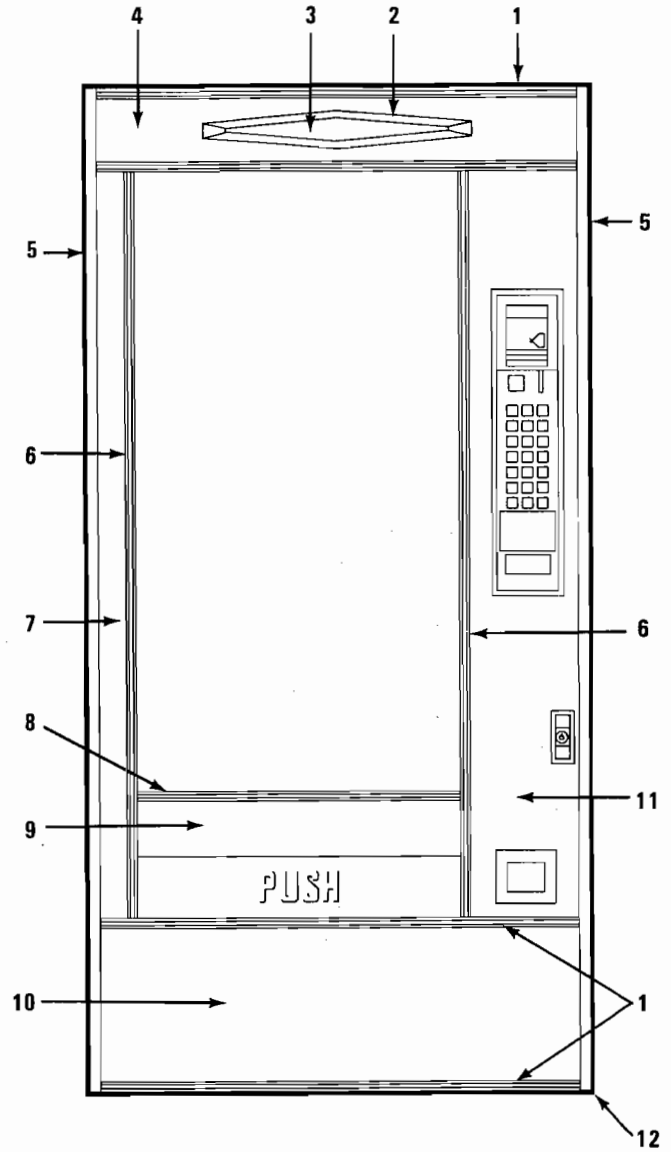

Item No.	Part No.	Description
1	660231-19	Trim, Horizontal, Bronze w/ Black Stripe.
2	660334-5	Frame, Top Trim.
3	440169	Frame, Top Inner.
4	440174	Frame, Top Inner Insert.
5	201015-3	Panel, Decorative Assy. (Cane).
6	340057-1	Trim, Outside Vertical. Bronze. Right or Left.
7	340058-11	Trim, Inside Vertical. Bronze. Right or Left.
8	200792-49	Panel, Left Side Vertical. Presidential Walnut.
9	340058-13	Trim, Inside Horizontal. Bronze.
10	201356-8	Panel, Delivery Tray. Presidential Walnut.
11	660334-11	Frame, Bottom.
	201-6R7	Screw, Rd. Hd. Phillips (6-18 x 7/16).
	201-6R5	Screw, Rd. Hd. Phillips (6-18 x 5/16).
	211-6R6	Screw, Truss Hd. Type B (#6-18).
12	201203-1	Panel, Lower Horizontal (Cane).
13	460237	Handle, Decal.
14	201357-23	Panel, Right Side Vertical. Presidential Walnut.
15	600431	Door Only, Specify Color.

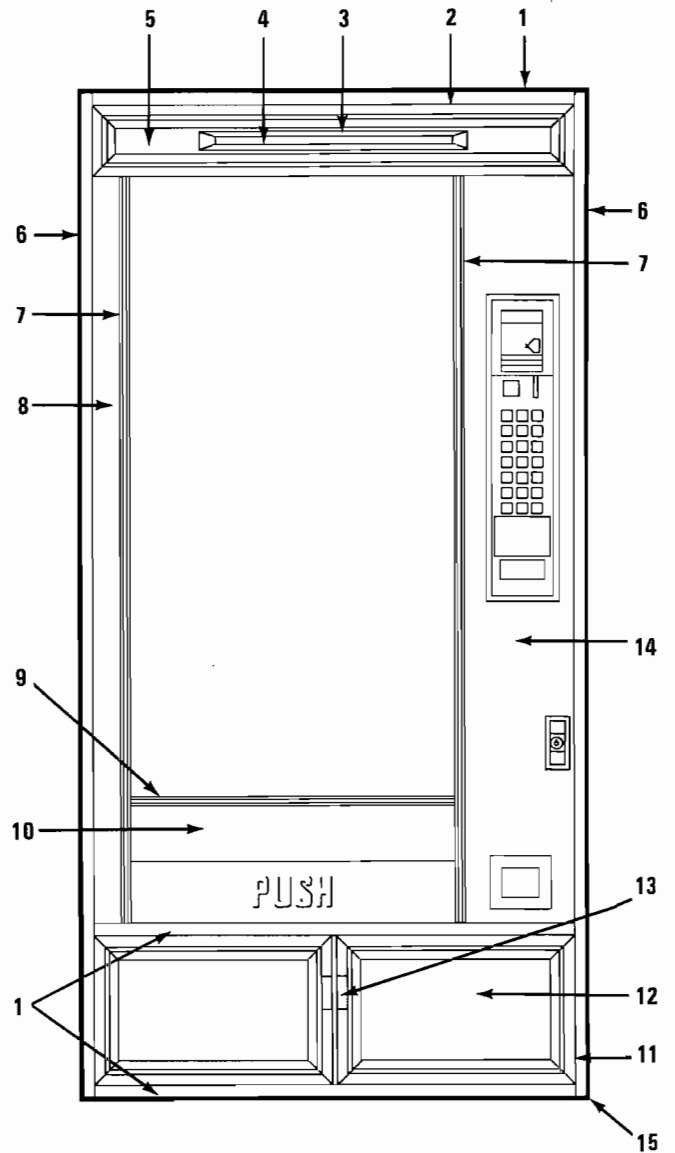

award style

Item No.	Part No.	Description
1	340042-6	Trim, Top Only.
2		Vinyl, Insert. Top Trim.
	200526-17	Honeytone Teak, Vinyl.
	200526-18	Imperial Rosewood Vinyl.
3	660231-20	Trim, Outside Vertical w/Black Stripe. Right or Left.
4	340058-6	Trim, Inside Vertical, Black. Right or Left.
5		Panel, Left Side Vertical.
	200792-37	Honeytone Teak Vinyl.
	200792-39	Imperial Rosewood Vinyl.
6	340058-12	Trim, Inside Horizontal, Black.
7		Panel, Delivery Tray.
	201356-11	Honeytone Teak Vinyl.
	201356-13	Imperial Rosewood Vinyl.
8	340055-15	Trim, Inside Horizontal, Black.
9		Panel, Right Side Vertical.
	201692-10	Honeytone Teak Vinyl.
	201692-12	Imperial Rosewood Vinyl.
	201678-2	Bottom Vinyl Door Edging (Not Shown).
	420186	Screw, Hwh Drill Pt. Black, (6-20 x 1/2) Qty 4.
10		Panel, Right Side Vertical.
	201357-47	Gray Vinyl.
11	600429	Door Only, Specify Color.

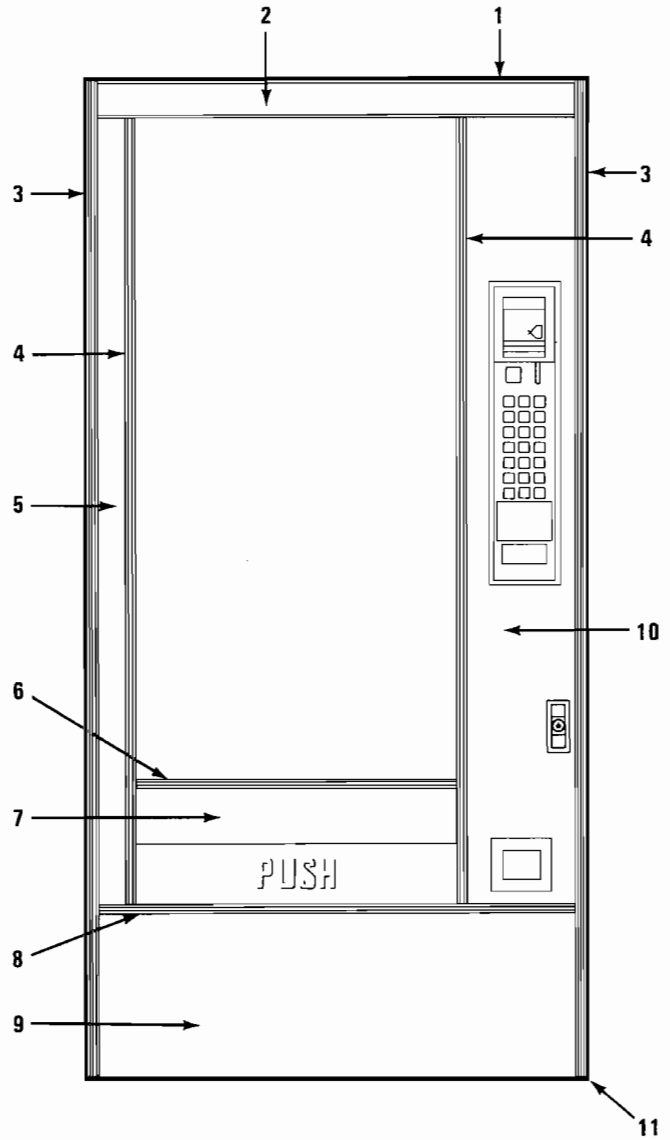

award style II

Item No.	Part No.	Description
1	340042-6	Trim, Top Only.
2		Vinyl Insert. Top Trim.
	200526-17	Honeytone Teak. Vinyl.
	200526-18	Imperial Rosewood Vinyl.
3	340057	Trim, Outside Vertical. Right or Left.
4	340058-7	Trim, Inside Vertical. Right or Left.
5	200792-101	Gray Vinyl.
6	340058-1	Trim, Inside Horizontal.
7	201356-21	Delivery Tray Panel. Gray Vinyl.
8	340055-6	Trim, Inside Horizontal.
9		Panel, Lower Horizontal.
	201692-10	Honeytone Teak Vinyl.
	201692-12	Imperial Rosewood Vinyl.
	201678-2	Bottom Vinyl Door Edging (Not Shown).
	420186	Screw, Hwh Drill Pt. Blk. (6-20 x 1/2) Qty. 4.
10		Panel, Right Side Vertical.
	201357-47	Gray Vinyl.
11	600429	Door Only. Specify Color.

Item No.	Part No.	Description
1	660231-19	Trim, Horizontal, Bronze w/ Black Stripe.
2	660334-5	Frame, Top Trim.
3	440169	Frame, Top Inner.
4	440174	Frame, Top Inner Insert.
5	201015-3	Panel, Decorative Assy. (Cane).
6	340057-1	Trim, Outside Vertical. Bronze. Right or Left.
7	340058-11	Trim, Inside Vertical. Bronze. Right or Left.
8	200792-49	Panel, Left Side Vertical. Presidential Walnut.
9	340058-13	Trim, Inside Horizontal. Bronze.
10	201356-8	Panel, Delivery Tray. Presidential Walnut.
11	660334-11	Frame, Bottom.
	201-6R7	Screw, Rd. Hd. Phillips (6-18 x 7/16).
	201-6R5	Screw, Rd. Hd. Phillips (6-18 x 5/16).
	211-6R6	Screw, Truss Hd. Type B (#6-18).
12	201203-1	Panel, Lower Horizontal (Cane).
13	460237	Handle, Decal.
14	201357-23	Panel, Right Side Vertical. Presidential Walnut.
15	600431	Door Only, Specify Color.

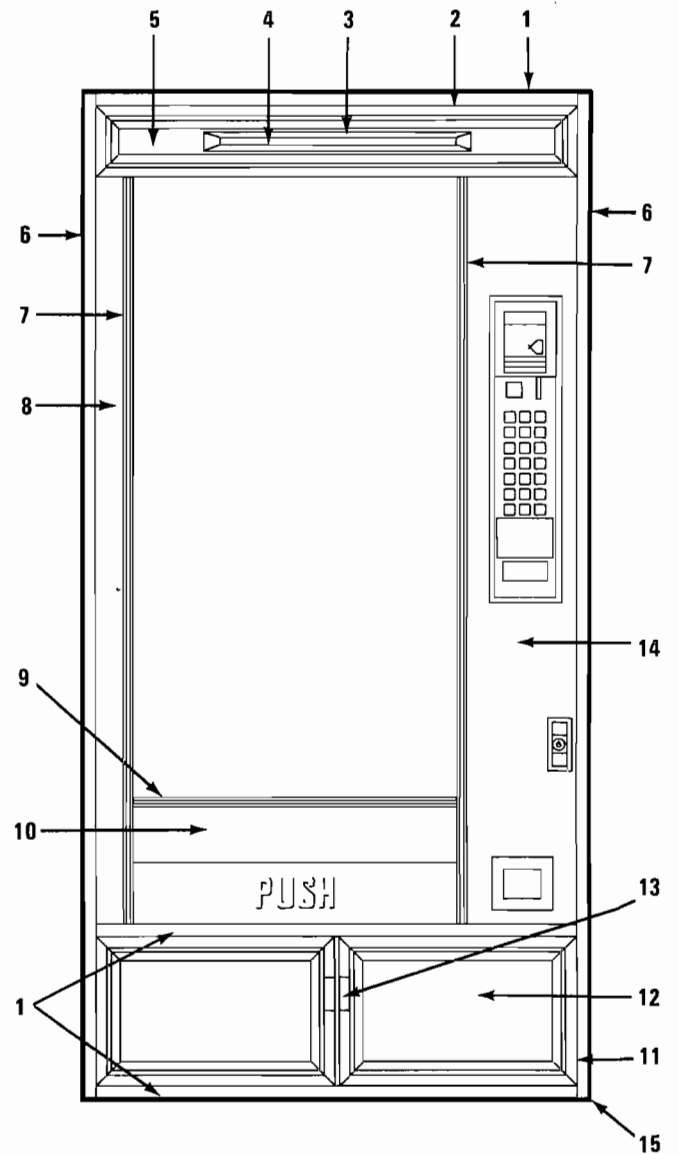

award style

Item No.	Part No.	Description
1	340042-6	Trim, Top Only.
2		Vinyl, Insert. Top Trim.
	200526-17	Honeytone Teak, Vinyl.
	200526-18	Imperial Rosewood Vinyl.
3	660231-20	Trim, Outside Vertical w/Black Stripe. Right or Left.
4	340058-6	Trim, Inside Vertical, Black. Right or Left.
5		Panel, Left Side Vertical.
	200792-37	Honeytone Teak Vinyl.
	200792-39	Imperial Rosewood Vinyl.
6	340058-12	Trim, Inside Horizontal, Black.
7		Panel, Delivery Tray.
	201356-11	Honeytone Teak Vinyl.
	201356-13	Imperial Rosewood Vinyl.
8	340055-15	Trim, Inside Horizontal, Black.
9		Panel, Right Side Vertical.
	201692-10	Honeytone Teak Vinyl.
	201692-12	Imperial Rosewood Vinyl.
	201678-2	Bottom Vinyl Door Edging (Not Shown).
	420186	Screw, Hwh Drill Pt. Black, (6-20 x 1/2) Qty 4.
10		Panel, Right Side Vertical. Gray Vinyl.
11	201357-47 600429	Door Only, Specify Color.

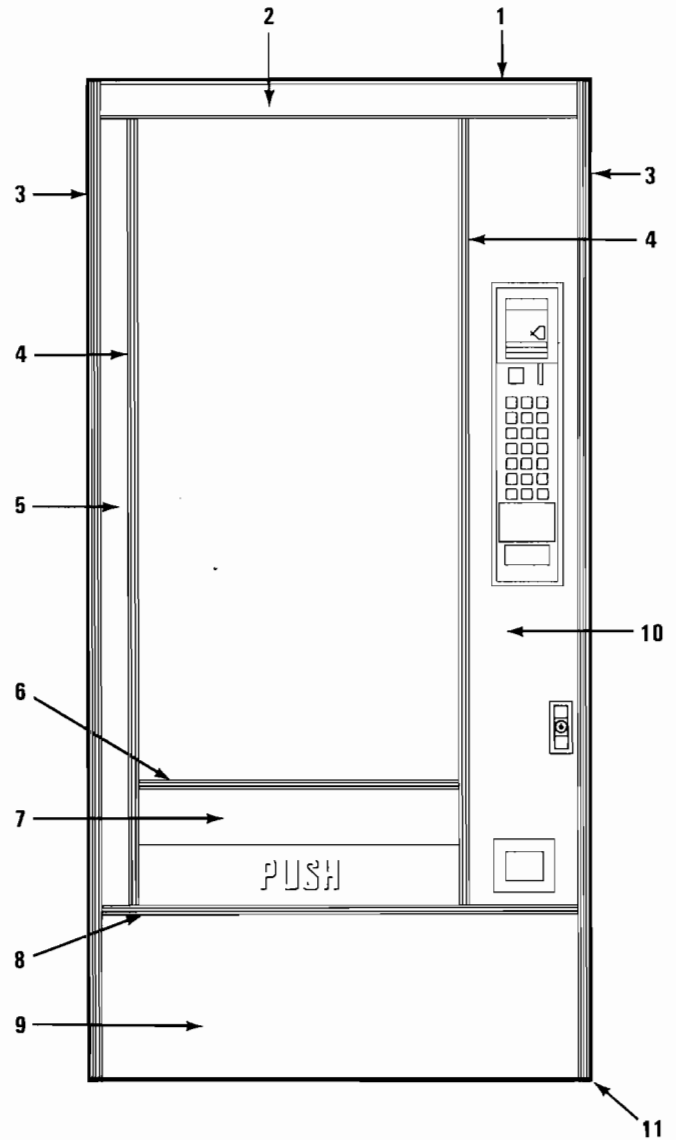

award style II

Item No.	Part No.	Description
1	340042-6	Trim, Top Only.
2		Vinyl Insert. Top Trim.
	200526-17	Honeytone Teak. Vinyl.
	200526-18	Imperial Rosewood Vinyl.
3	340057	Trim, Outside Vertical. Right or Left.
4	340058-7	Trim, Inside Vertical. Right or Left.
5	200792-101	Gray Vinyl.
6	340058-1	Trim, Inside Horizontal.
7	201356-21	Delivery Tray Panel. Gray Vinyl.
8	340055-6	Trim, Inside Horizontal.
9		Panel, Lower Horizontal.
	201692-10	Honeytone Teak Vinyl.
	201692-12	Imperial Rosewood Vinyl.
	201678-2	Bottom Vinyl Door Edging (Not Shown).
	420186	Screw, Hwh Drill Pt. Blk. (6-20 x 1/2) Qty. 4.
10		Panel, Right Side Vertical.
	201357-47	Gray Vinyl.
11	600429	Door Only. Specify Color.

Item No.	Part No.	Description
1	340042-7	Trim, Top Only.
2	200526-19	Vinyl, Insert. Top Trim. Wheatstone.
3	340057-1	Trim, Outside Vertical. Right or Left.
4	340058-14	Trim, Inside Vertical. Right or Left.
5		Panel, Left Side Vertical.
	200792-99	Bronze.
6		Panel, Right Side Vertical
	201357-46	Bronze.
7	340058-13	Trim, Inside Horizontal.
8		Panel, Delivery Tray.
	201356-19	Bronze.
9	340055-7	Trim, Inside Horizontal.
10		Panel, Lower Horizontal.
	201692-24	Wheatstone.
	201678-2	Bottom Vinyl Door Edging (Not Shown).
	420186	Screw, Hwh Drill Pt. Blk. (6-20 x 1/2) Qty. 4.
11	600429	Door Only, Specify Color.

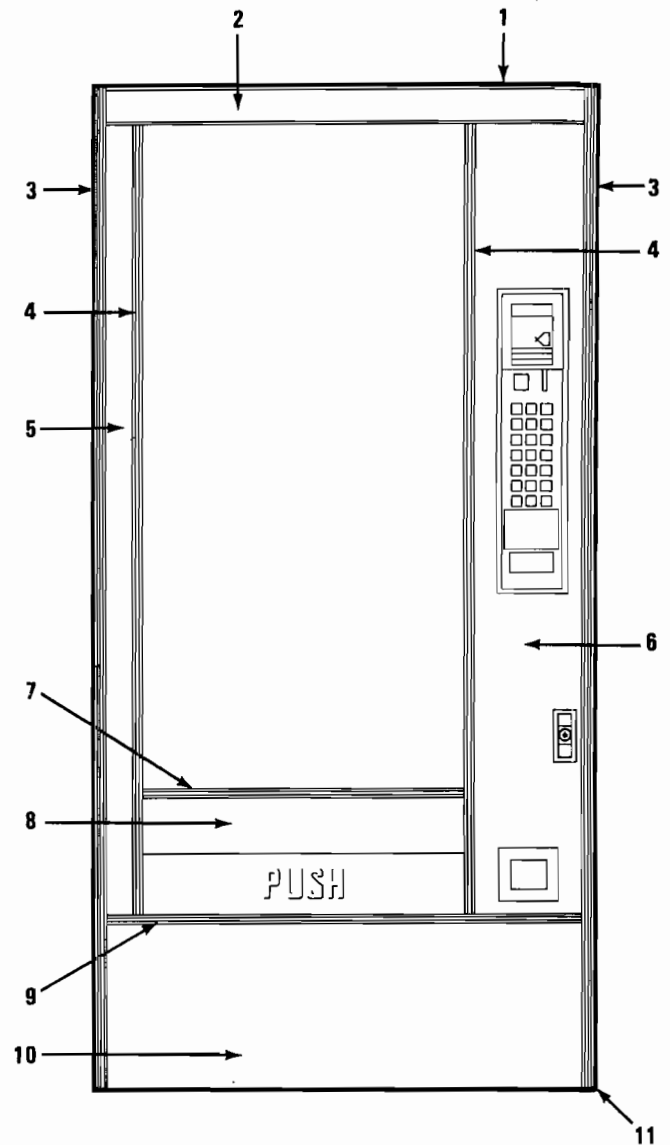

hi-tech style

Item No.	Part No.	Description
1	340042-6	Trim, Top Only.
2		Vinyl Insert, Top Trim.
	201260-2	Snacks.
3	340057-2	Trim, Outside Vertical Black. Right or Left.
4	340058-7	Trim, Inside Vertical. Right or Left.
5		Panel, Left Side Vertical Stainless Vinyl.
	200792-40	
6	340058-1	Trim, Inside Horizontal.
7		Panel, Delivery Tray .
	201356-15	Stainless Vinyl.
8	340055-6	Trim, Inside Horizontal.
9		Panel, Lower Horizontal.
	201692-27	Stainless Vinyl.
10		Panel, Right Side Vertical.
	201357-14	Stainless Vinyl.
	201678-2	Bottom Vinyl Door Edging (Not Shown).
	420186	Screw, Hwh Drill Pt. Blk. (6-20 x 1/2) Qty. 4.
11	600429	Door Only, Specify Color.

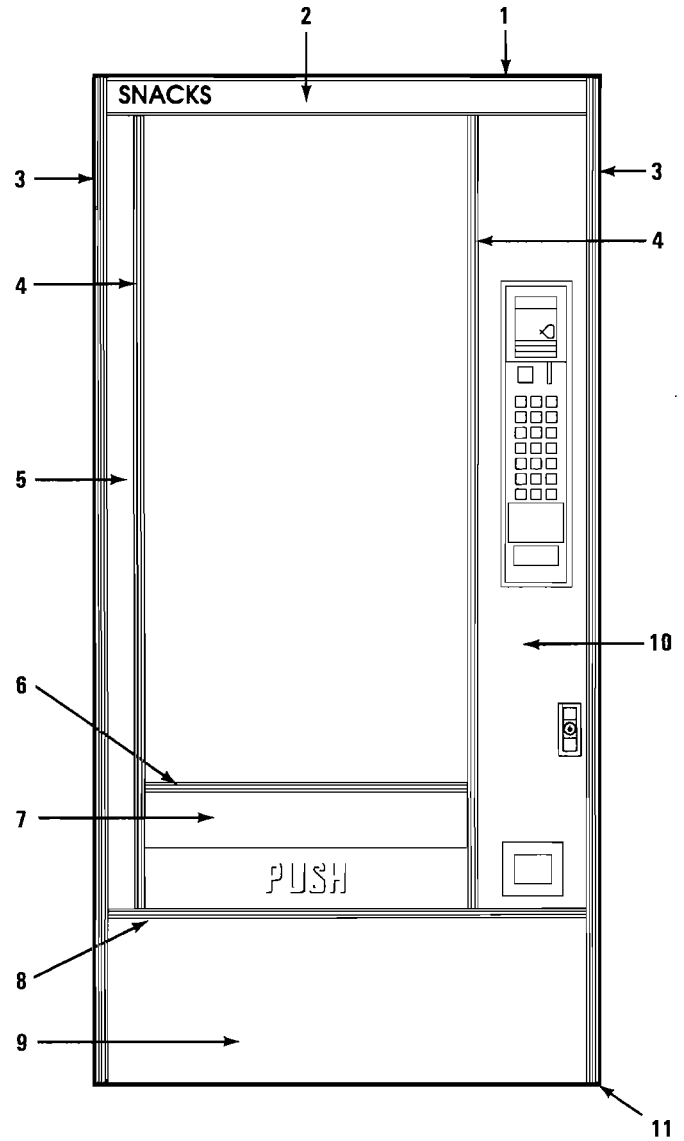

Item No.	Part No.	Description
1	201417-11	Panel, Top, Cane Vinyl.
2	660231-1	Trim, Horizontal w/Black Stripe Top or Bottom.
3	340057-1	Trim, Outside Vertical Bronze. (Right or Left)
4	340058-15	Trim, Inside Vertical, Bronze. (Right or Left)
5		Panel, Left Side Vertical.
6	200792-56	Presidential Walnut, Vinyl.
7	340058-13	Trim, Inside Horizontal, Bronze.
8		Panel, Delivery Tray.
9	201356-8	Presidential Walnut, Vinyl.
10	660334-11	Frame Bottom.
11	201-6R12	Screw, Rd. Hd. Phillips (#6-18 x 3/4).
12	201-6R7	Screw, Rd. Hd. Phillips (#6-18 x 7/16).
	200-6R6	Screw, Rd. Hd. Phillips (#6-18 x 3/8).
	420101	Nut, Pal Plastic Boss
	201203-1	Panel, Lower Horizontal. Cane, Vinyl.
	460237	Handle, Decal.
		Panel, Right Side Vertical.
	201357-30	Presidential Walnut, Vinyl.
	600431	Door Only. Specify Color.

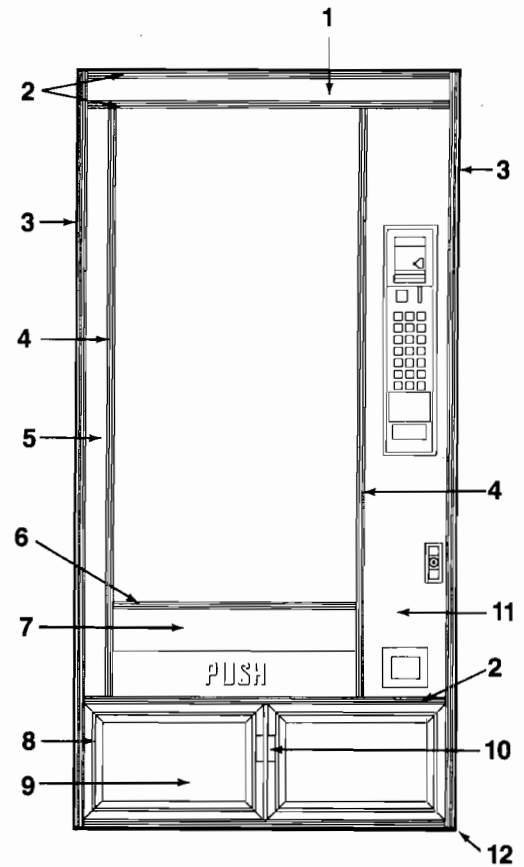

golden tron style II

Item No.	Part No.	Description
1	340055-15	Trim Horizontal, Top & Bottom, Black.
2	201417-3	Cover Up Plate, Galvanized.
3	440312	Top Insert, Black.
4	340055-6	Trim, Horizontal.
5	340057-2	Trim, Outside Vertical, Left or Right, Black.
6	340058-4	Trim, Inside Vertical, Left or Right.
7	200792-107	L S V P Dove Gray Tron.
8	340058-1	Trim, Horizontal, Window.
9	201356-15	Delivery Tray Panel, Stainless.
10	200296-10	Panel, Lower Horizontal, Dove Gray Tron.
11	201357-52	R S V P Dove Gray Tron

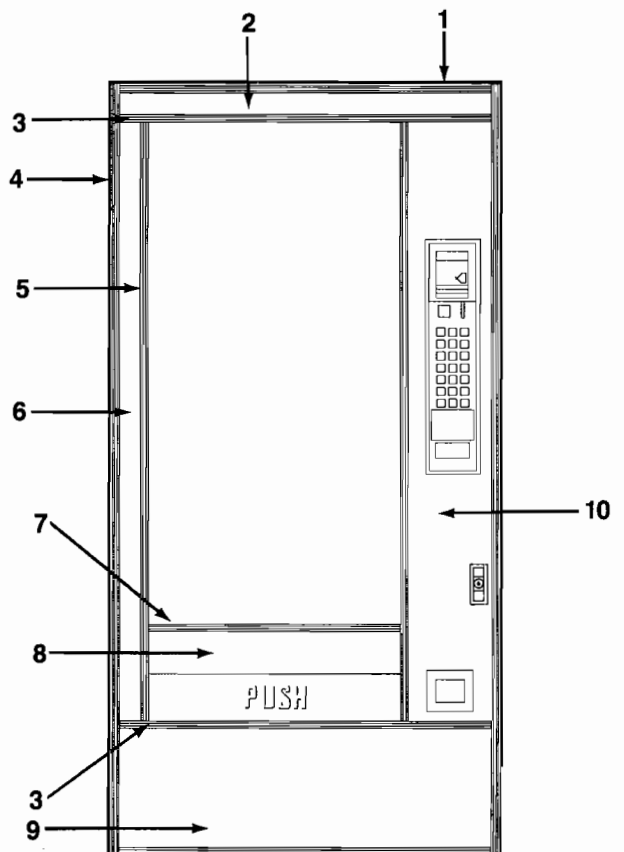

connectors



CABLE TIE
460044



**MOUNTING TYPE
CABLE TIE**
380078



**ADHESIVE BACKED
CORD CLIP**
420097

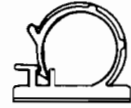

**ADHESIVE BACKED
CABLE CLAMP**
420096



**FEMALE QUICK
DISCONNECT TERMINAL**
9/64 – 380213
3/16 – 380001
1/4 – 380003



**FEMALE PLUG
TERMINAL**
LARGE – 380004
SMALL – 380129



MALE PLUG TERMINAL
LARGE – 380005
SMALL – 380130



SQUARE PIN TERMINAL
LARGE – 380211
SMALL – 380208

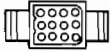

**MOLEX MALE
CONNECTOR**
3 PIN – 380034
6 PIN – 380106

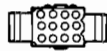

**MOLEX FEMALE
CONNECTOR**
2 PIN – 380189
3 PIN – 380035
6 PIN – 380107

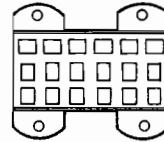

**MAIN PRODUCT SHELF
RECEPTACLE**
380238

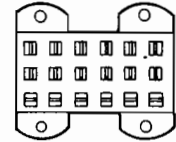

**MAIN PRODUCT SHELF
PLUG**
380237



**AMP IN-LINE
CONNECTOR**
.156 CTRS.
7 PIN – 380210
18 PIN – 380210-1
13 PIN – 380210-2
17 PIN – 380210-3
19 PIN – 380210-4

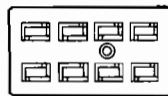

**CHANGER
RECEPTACLE
AND COVER**
18 PIN – 380199
COVER – 380125
12 PIN – 380200
COVER – 380201



**WIRE
CONNECTOR**
380214



CABLE CLAMP
3/8 DIA.
420035-1

MOLEX CONNECTOR
.100 CTRS.
17 PIN – 380207



METAL CABLE CLAMP
420088



**CONNECTOR
POLARIZING KEY**
.100 CTRS – 380209
.156 CTRS – 380212

troubleshooting

TROUBLE	CAUSE	REMEDY
Motor runs (2½ turns).	<ol style="list-style-type: none"> 1. Capacitor discharging current. 2. Defective motor, control board, or motor switch. 3. Loose wire on motor. 4. Defective motor switch. 	<ol style="list-style-type: none"> 1. Resolder capacitor or replace motor. 2. Replace motor, control board, or motor switch. 3. Replace wire. 4. Replace switch.
Motors appear defective.	<ol style="list-style-type: none"> 1. Defective transformer. 2. Defective circuit breaker. 3. Pin connection. 	<ol style="list-style-type: none"> 1. Check for 28 volts from transformer to control board.
Spirals turn continuously.	<ol style="list-style-type: none"> 1. Defective control board. 	<ol style="list-style-type: none"> 1. Replace board.
Motors run on same number throughout machine A1, B1, C1, D1, E1, F1.	<ol style="list-style-type: none"> 1. One of the motor wires is shorting out. 	<ol style="list-style-type: none"> 1. Check each individual motor for loose or pinched wire and replace it.
Cannot set prices in machine.	<ol style="list-style-type: none"> 1. Defective selection switch panel. 2. Defective control board. 	<ol style="list-style-type: none"> 1. Replace selection switch panel. 2. Replace board.
Push A & A1 turns. Push B & B1 turns.	<ol style="list-style-type: none"> 1. Selector switch panel shorting out. 	<ol style="list-style-type: none"> 1. Replace selector switch panel assembly.
No L.E.D. lights on control board.	<ol style="list-style-type: none"> 1. Check plugs on control board. 2. Defective control board 	<ol style="list-style-type: none"> 1. Plug in. 2. Replace board.
Press the service mode but cannot empty changer.	<ol style="list-style-type: none"> 1. Check plugs on the control board. 2. Defective changer. 3. Defective main power board. 	<ol style="list-style-type: none"> 1. Plug in. 2. Replace changer. 3. Replace board.
Machine will not accept coins.	<ol style="list-style-type: none"> 1. No power to machine. 2. Defective changer. 3. The changer will accept only logical amount of money above the vend price. 4. Changer should be installed with power off. 5. Machine accepts only one coin. 6. Defective power board. 7. Defective circuit breaker (115 volt). 	<ol style="list-style-type: none"> 1. Check wall outlet. 2. Replace changer. 3. Check pricing. 4. Turn power off—then on. 5. Check prices in the machine. Check for defective circuit breakers. 6. Replace power board. 7. Replace circuit breaker.
G&M selection shows "Make another selection"	<ol style="list-style-type: none"> 1. Defective motor. 2. Wire lettered "G" broken or cold soldered. 	<ol style="list-style-type: none"> 1. Replace motor. 2. Check for resistance from the G&M shelf plug to the control board.

